

The Changing Face of Communications



1

Migration to IP Networks

2

The Changing Face of the Internet

3

The Internet as a Value Added Platform

1 Migration to IP Networks

2 The Changing Face of the Internet

3 The Internet as a Value Added Platform

Five Major Technology Discontinuities Will Enable Convergence

Broadband

2 Everywhere



3 Ubiquitous Wireless



1 IP networks



4 Multi-access innovative devices



5 Delayed and open network and IT platforms

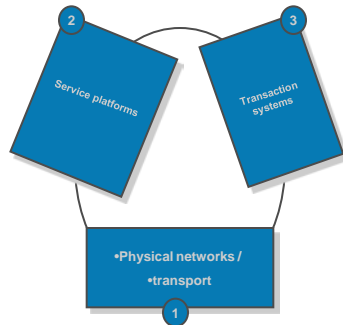

Convergence of Different Industries

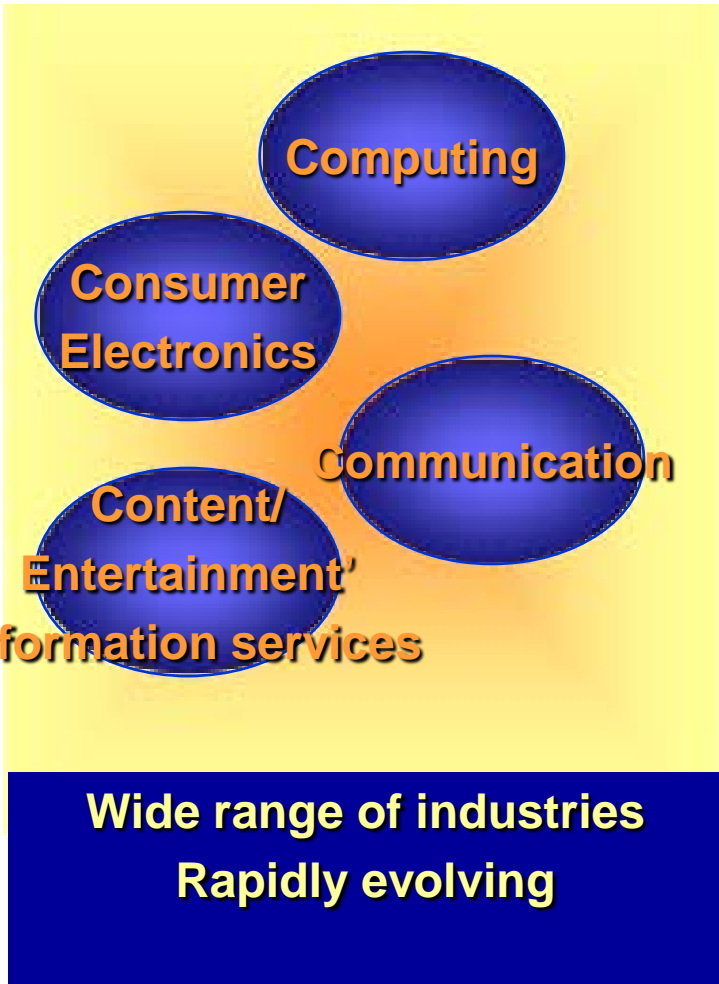

- Global Competition*
- Advances in Tech*
- Smarter Customers*
- De-regulation*

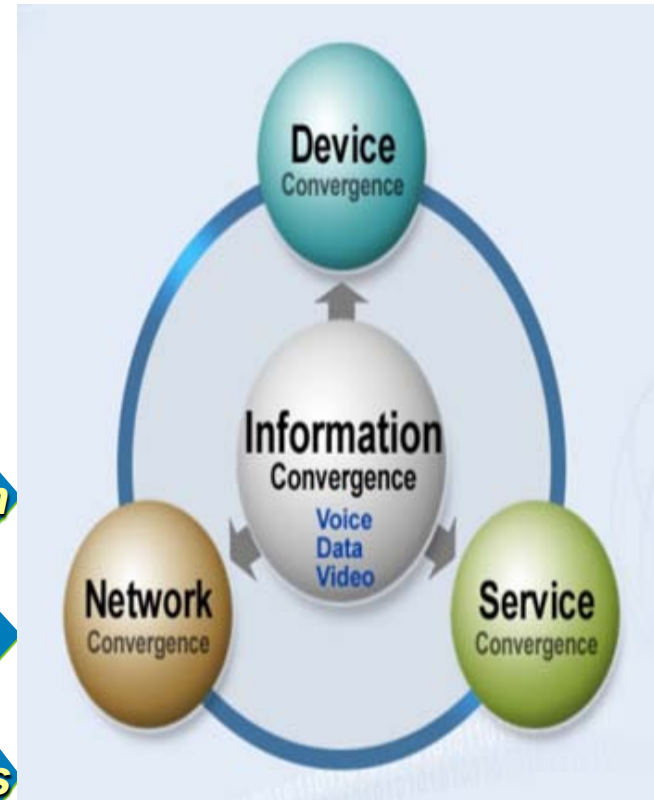

Network Convergence

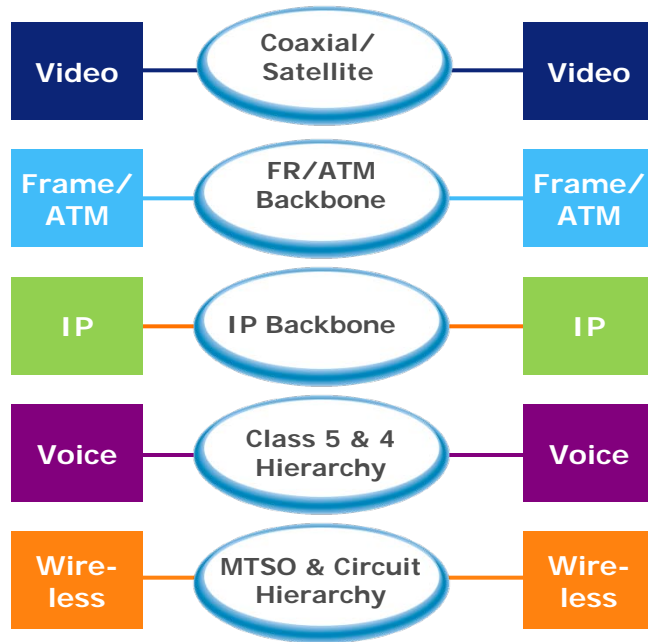

The Past

Multiple backbones for each access technology or service

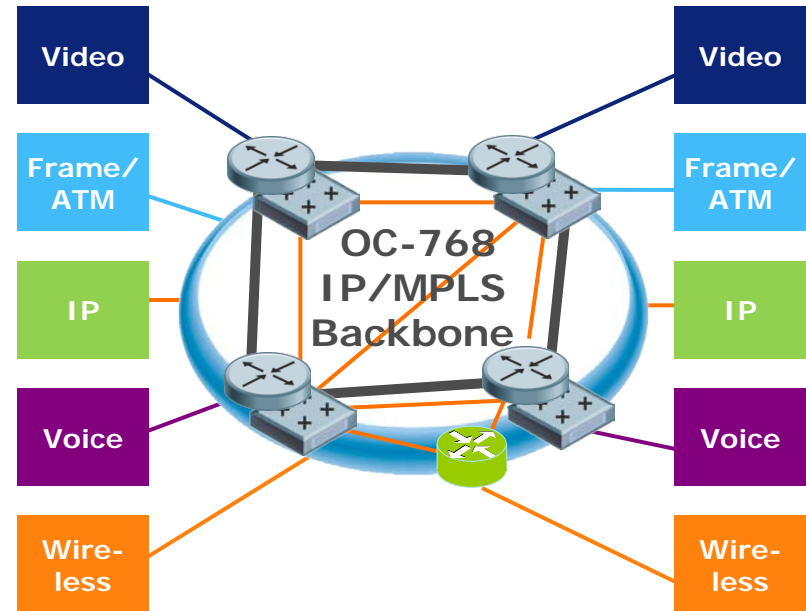

Today

Multiple access technologies & services on one IP-based backbone

Services over IP Vision – Layered

Integrated Feature Execution Environment

Collaboration



Voice



Conferencing



Messaging



Video



VoIP



IP Centrex



SoIP Infrastructure Provides Advanced Services In A Uniform Environment

Common SoIP Network Infrastructure

E911

Peering

Common Call Control

Network
Functions

CALEA

Border Elements & Gateways

All Access Technologies

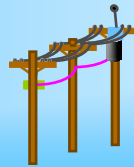

Any End Device



Everything Over IP

VoIP is the 1st “killer” application delivering voice communications and enabling voice convergence with other data applications and devices



WHAT THE FUTURE HOLDS:

- Presence (Instant Messenger, Follow me)
- One Number / “Follow Me” Services
- Click-to-Talk Interactive Call Centers
- Universal Messaging
- Virtual Meetings / Collaboration (like NetMeeting)
- Real time language translation
- IP Centrex in a Box
- Multi-Point Videoconferencing
- Desktop Multimedia
- Push to Talk Cellular
- Voice Chat

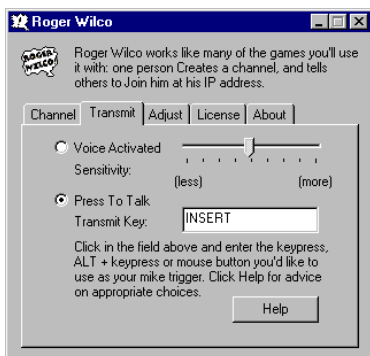
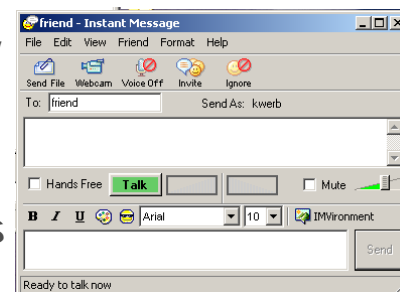

Voice Becomes Another Data Application On an IP Network

Internet Protocol (IP) separates applications from the network:

- Voice is not longer restricted to telephone networks
- Voice becomes another IP data application

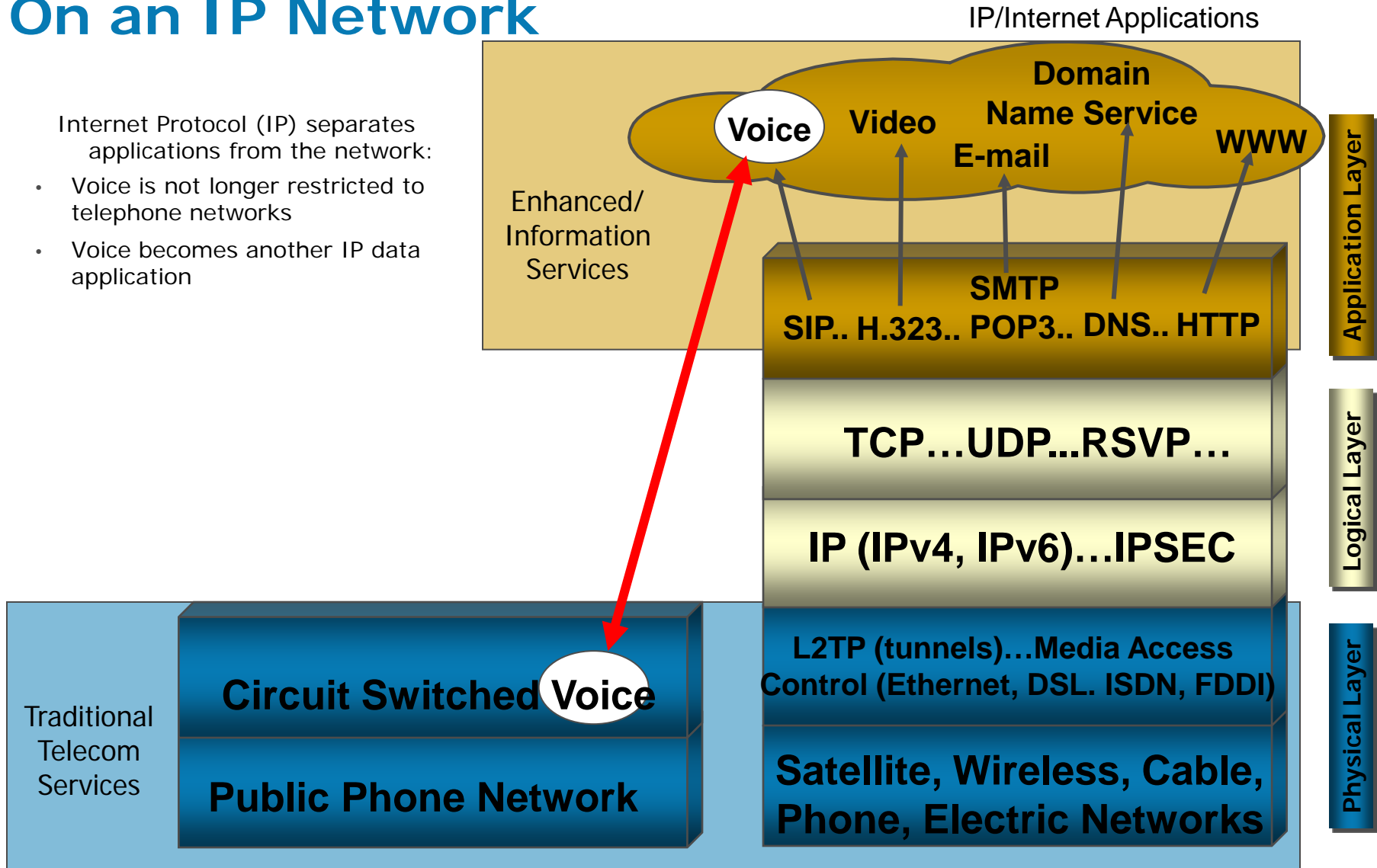

Video Becomes Another Data Application On an IP Network

Internet Protocol (IP) separates applications from the network:

- Video is not longer restricted to cable or Satellite networks
- Video becomes another IP data application

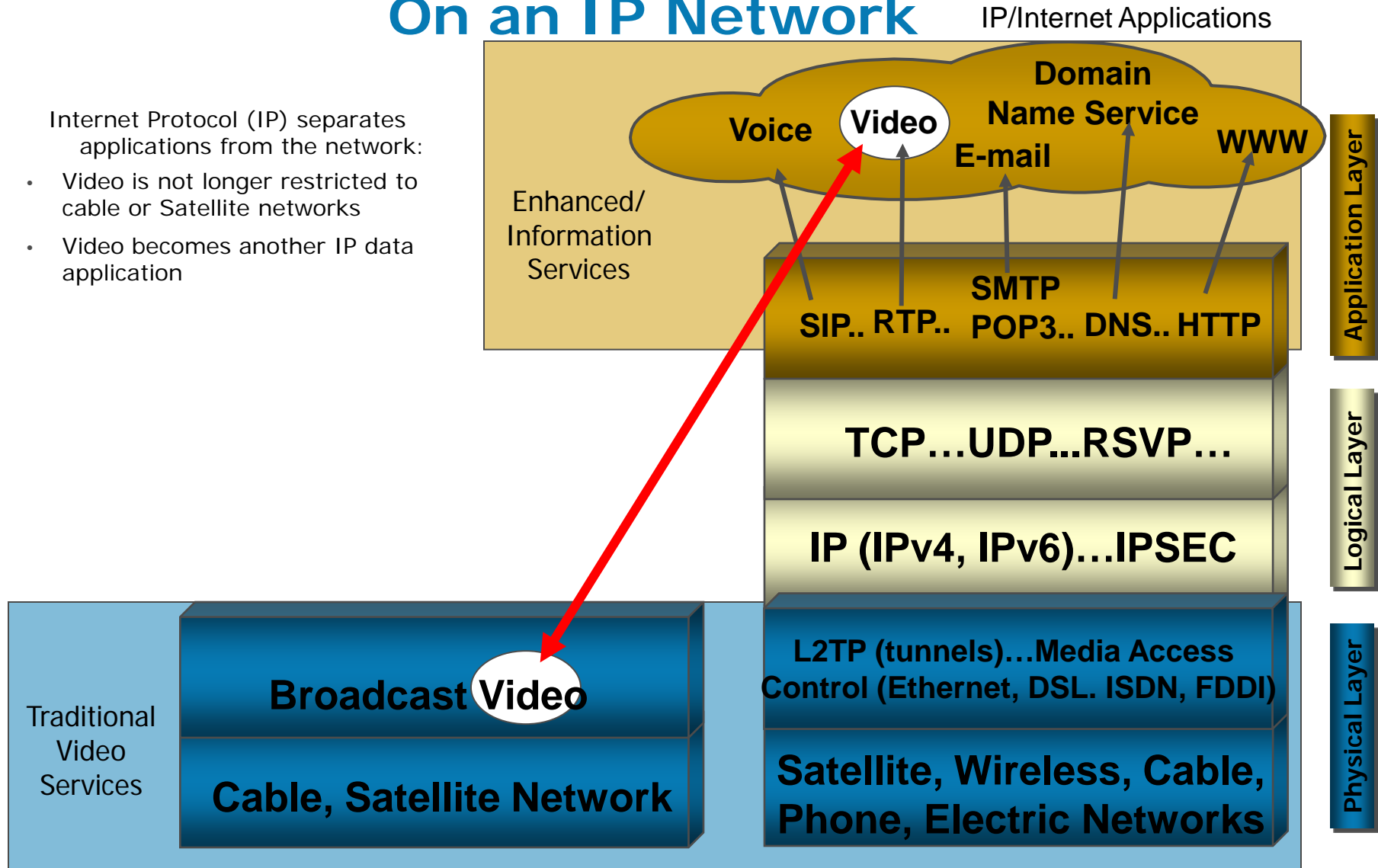

1 Migration to IP Networks

2 The Changing Face of the Internet

3 The Internet as a Value Added Platform

How Consumers "See" the Internet

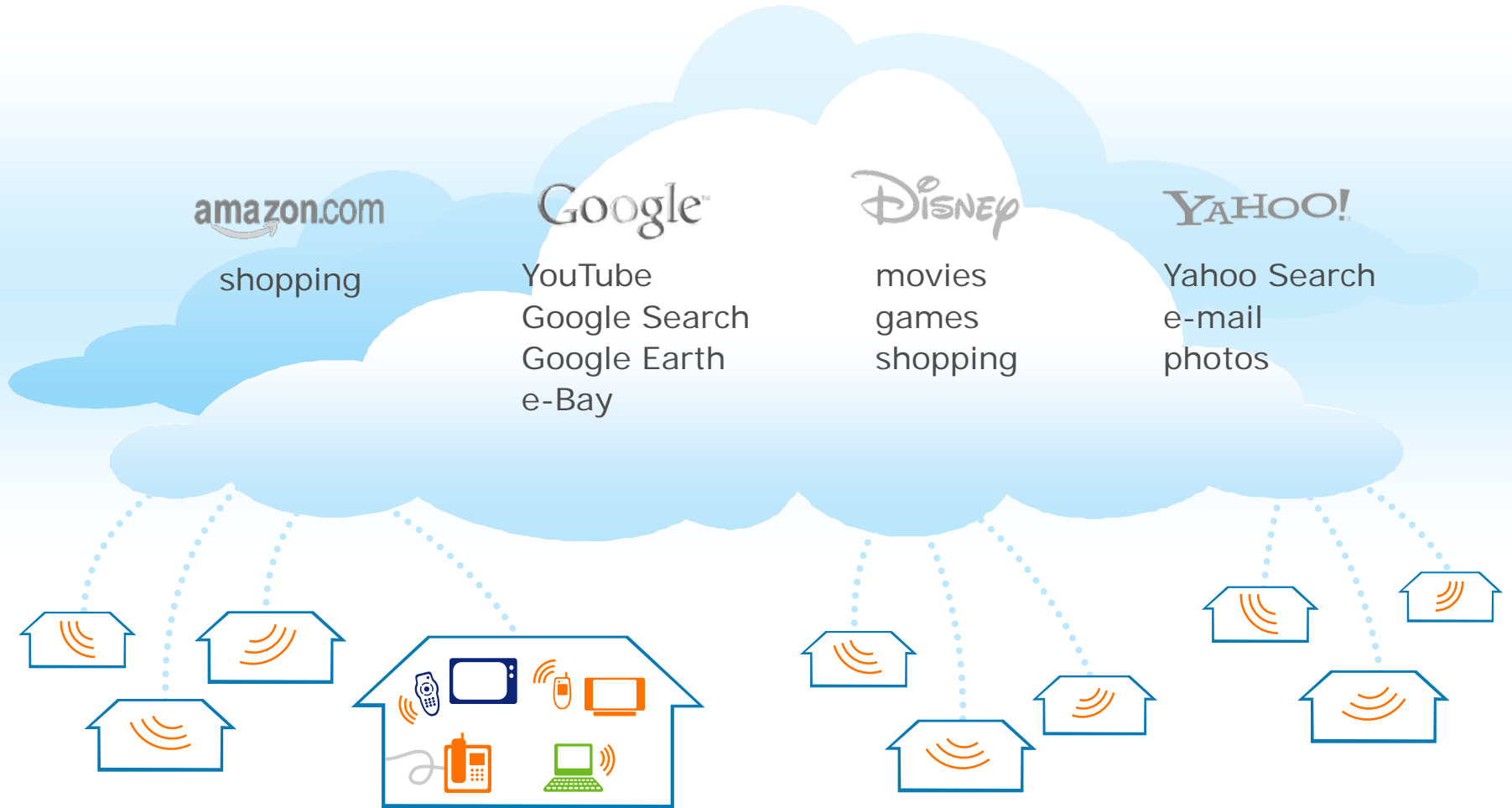

How the Internet Really Works

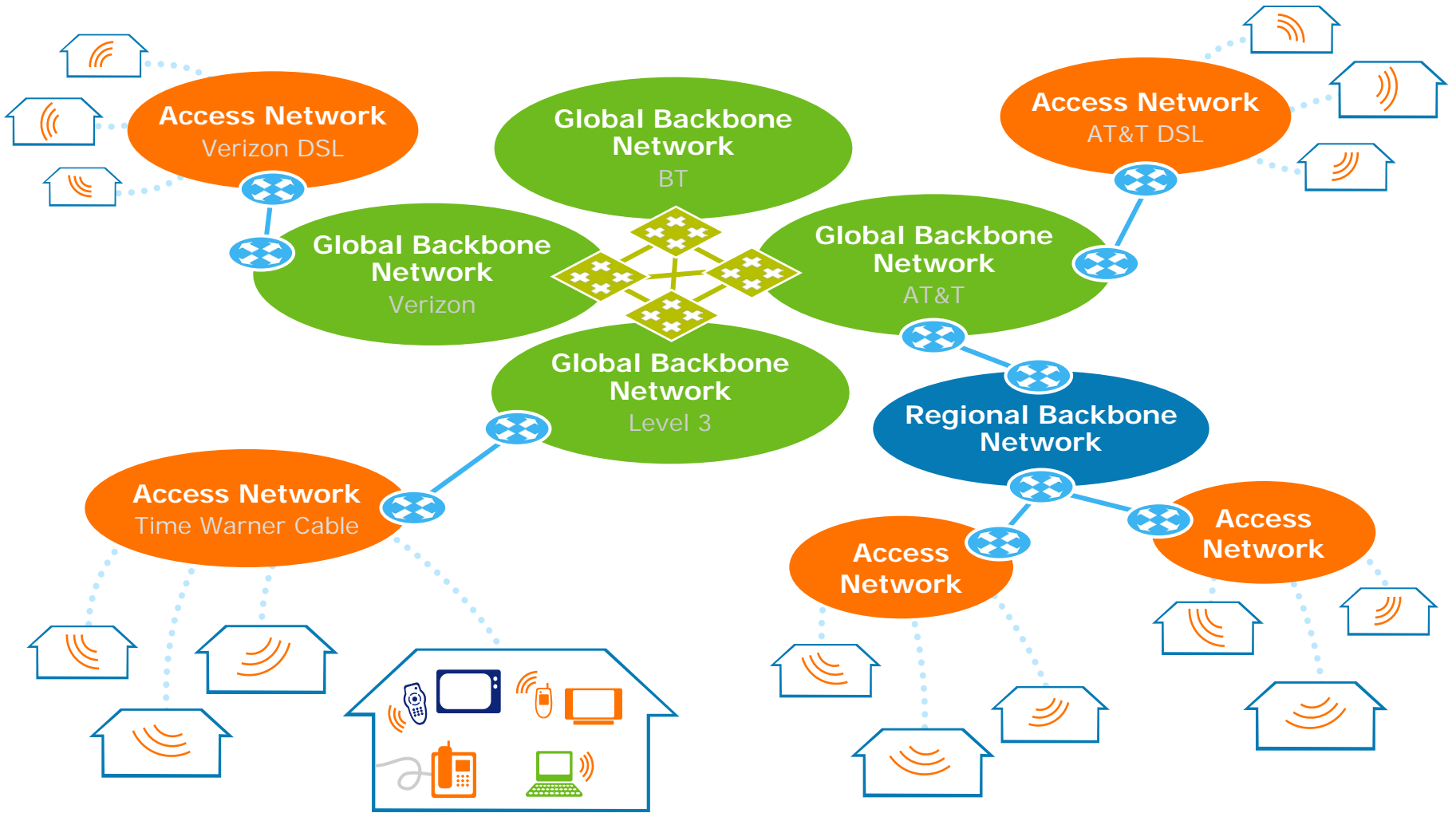

How the Internet Really Works

200,000+ private networks

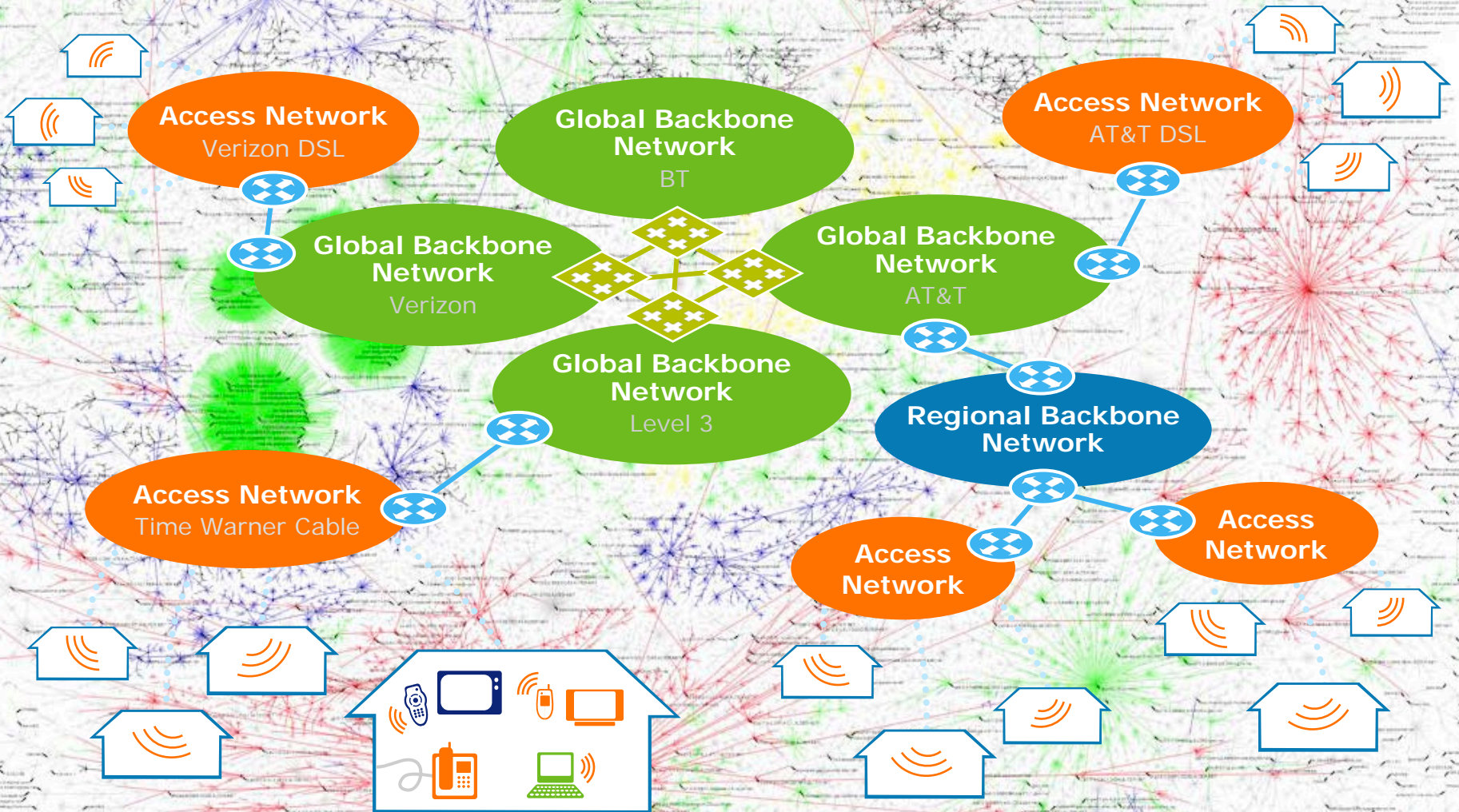

Source: Lumeta

© 2010

AT&T's IP Network is a Microcosm of the Internet

World Internet Topology

Brought to you by AT&T Labs
in partnership with QUANTERA

These statistics are based on the content of the central or largest node.
The size of the node represents the number of links connected to it. The size of the links represents the number of links connected to the node.
The size of the links represents the number of links connected to the node.
The size of the links represents the number of links connected to the node.

AT&T's Network by the Numbers.

9.81

Percentage of data transmitted across AT&T's network by the average business day. It is the equivalent of moving the entire contents of the Library of Congress away from its shelves.

1

AT&T's rank among broadband providers in the United States.

12.9 Million

AT&T's residential customer base in the United States.

540,000

AT&T's residential customer base in the United States.

\$6 Billion

AT&T's revenue in the United States in 2008.

36

AT&T's number of broadband providers in the United States.

301,760

AT&T's number of broadband providers in the United States.

97%

Percentage of the world's population that is online.

99.998%

AT&T's network reliability.

49,000

Number of AT&T's broadband providers in the United States.

166

Number of AT&T's broadband providers in the United States.

3 Million

AT&T's broadband customer base in the United States.

160%

AT&T's broadband customer base in the United States.

7

AT&T's broadband customer base in the United States.

2

AT&T's broadband customer base in the United States.



World Internet by the Numbers.

320,000

Number of IP addresses in the Internet.

48 Million

Number of IP addresses in the Internet.

1.133 Billion

Number of IP addresses in the Internet.

6.4 Million

Number of IP addresses in the Internet.

1.6 Billion

Number of IP addresses in the Internet.

40 Million

Number of IP addresses in the Internet.

35,000

Number of IP addresses in the Internet.

100 Million

Number of IP addresses in the Internet.

161

Number of IP addresses in the Internet.

12 Million

Number of IP addresses in the Internet.

15 Million

Number of IP addresses in the Internet.

\$72.5 Billion

Number of IP addresses in the Internet.



Where are We Today?

	2007	2010	% increase
Electronic data generated this year (exabytes)	38	180	374%
Internet users (billions)	1	1.8	80%
Youtube daily downloads (millions)	100	2000	1900%
Active Facebook Users (millions)	50	400	700%
Tweets per Day (thousands)	5	50,000	999,900%

AT&T's Traffic Growth

AT&T IP Backbone:
Traffic Trends 2008-2013; 750% growth projected

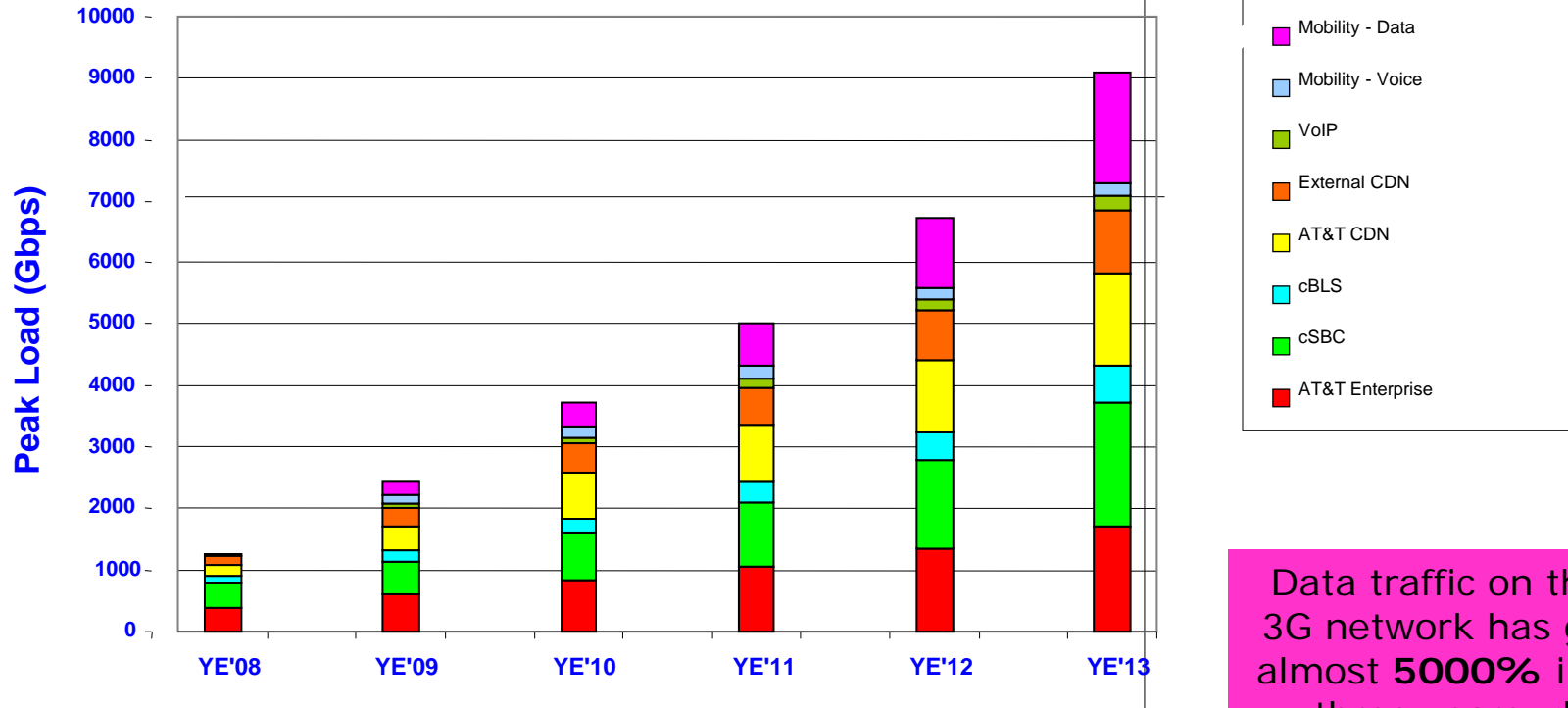

Data traffic on the AT&T 3G network has grown by almost **5000%** in the last three years, due to:

- 8.3 million smartphones,
- mobile broadband,
- e-mail
- M2M connections

The Internet Tomorrow: Connecting Billions of Devices through IP

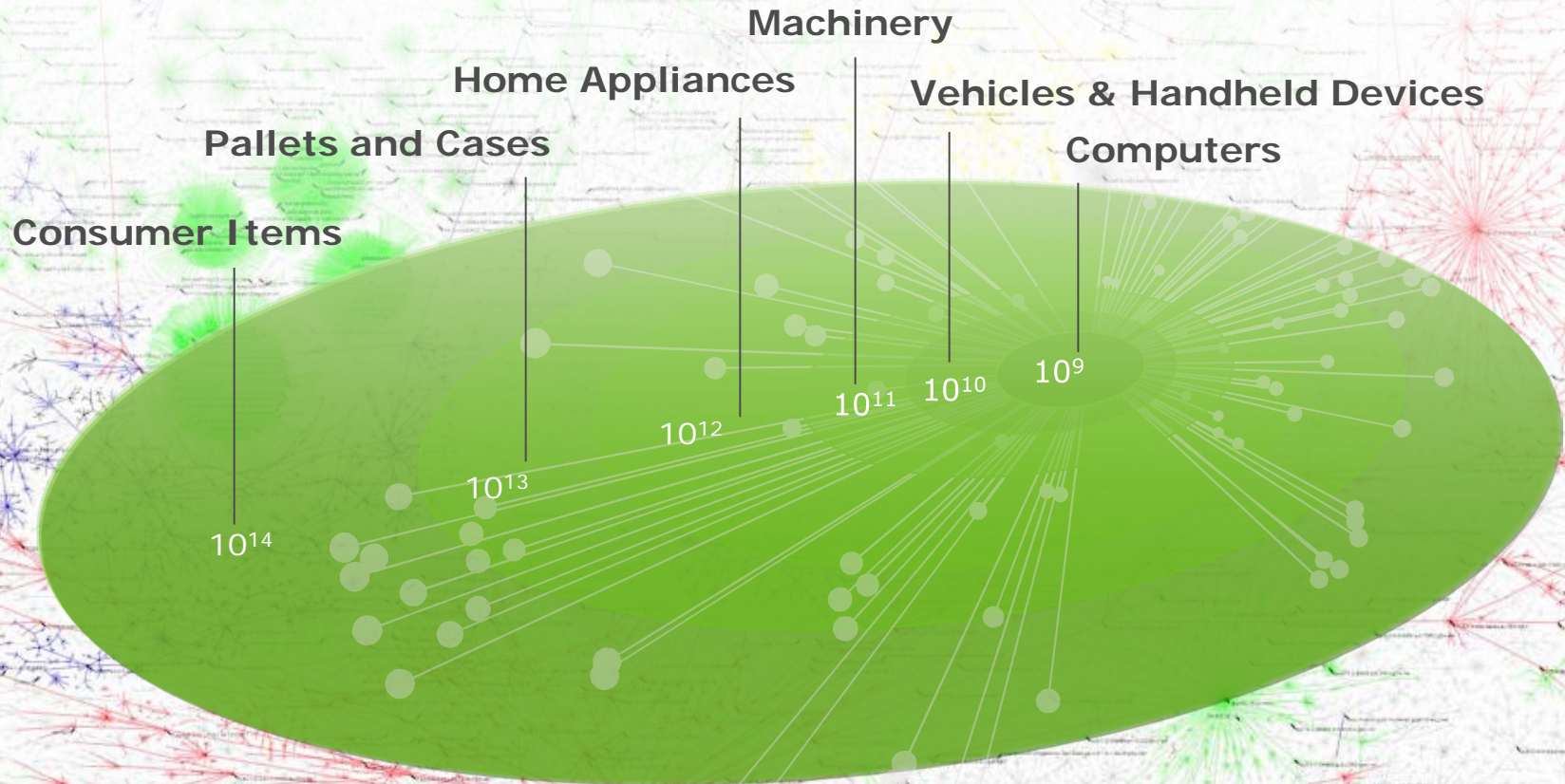

Worldwide Mobile Subscribers: 4 billion subscribers Dec '08

- Strategy Analysts predict 5.8 billion by 2013
- 1 in 4 US households has a cell phone, but no landline
- 286 million mobile phones in US
- For the first time ever, on a global basis mobile phones were used more for accessing data than they were to make calls, and that global data traffic exceeded an Exabyte of data. (moconews.net 4/1/2010)

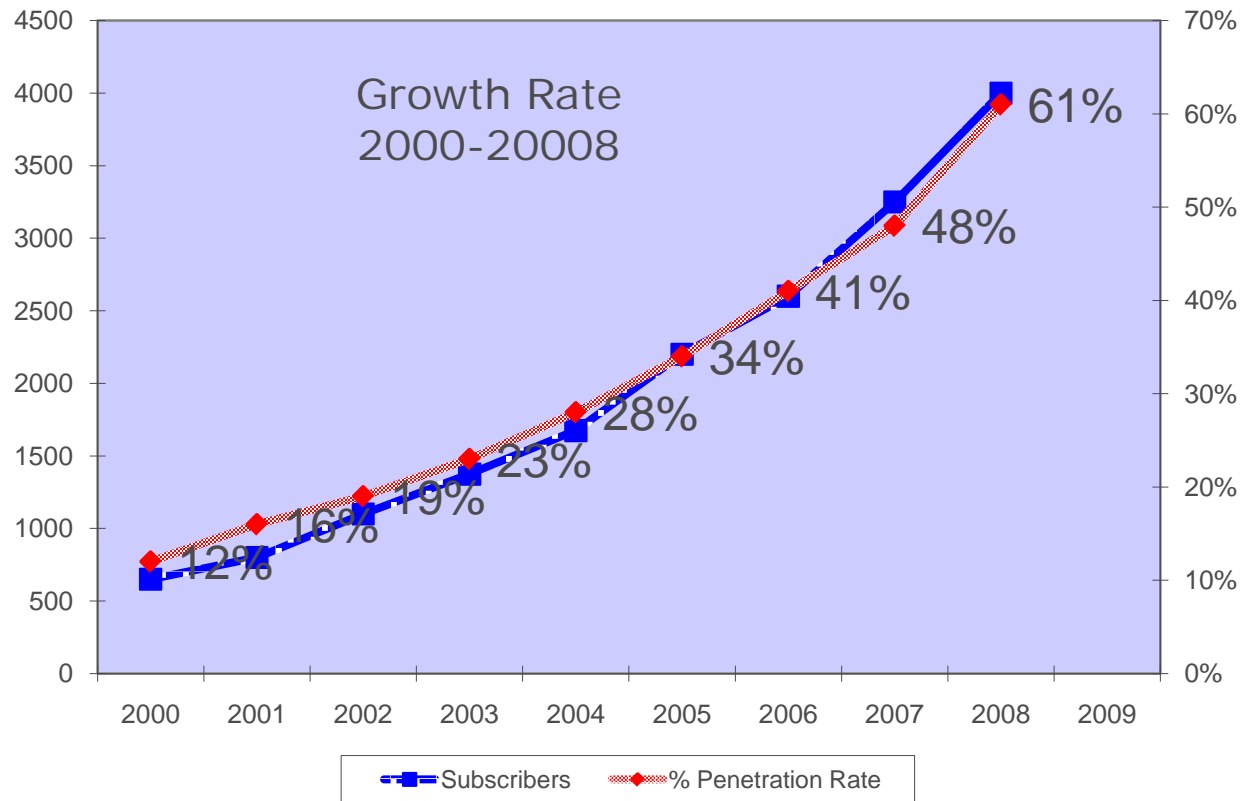

Graph: www.itu.org; Estimates: Strategy Analysts

1 What is the Internet?

2 The Changing Face of the Internet

3 The Internet as a Value Added Platform

Connectivity >> Velocity



>> Drives Economic Growth

What the Internet Does

Provides a value-added platform to deliver content & services at lower cost to consumers

Distributed Data

Distributed
Text

Distributed
Content:
WWW

Distributed
Voice

Distributed
Video



What the Internet Does

Provides a value-added platform to deliver content & services at lower cost to consumers

Distributed Data

Distributed Text

Distributed Content:
WWW

Distributed Voice

Distributed Video

- E-mail
- Instant messaging
- Text messaging
- E-collaboration/
e-work
- Blogs



What the Internet Does

Provides a value-added platform to deliver content & services at lower cost to consumers

Distributed Data

Distributed Text

Distributed Content:
WWW

Distributed Voice

Distributed Video



- Music
- Software distribution
- Retail sales
- Public information
- Games
- Books
- Publishing



What the Internet Does

Provides a value-added platform to deliver content & services at lower cost to consumers

Distributed Data

Distributed Text

Distributed Content:
www

Distributed Voice

Distributed Video



- VoIP phone calling
- Chat
- Audio conferencing
- Answering services
- Record and send



What the Internet Does

Provides a value-added platform to deliver content & services at lower cost to consumers

Distributed Data

Distributed Text

Distributed Content:
www

Distributed Voice

Distributed Video

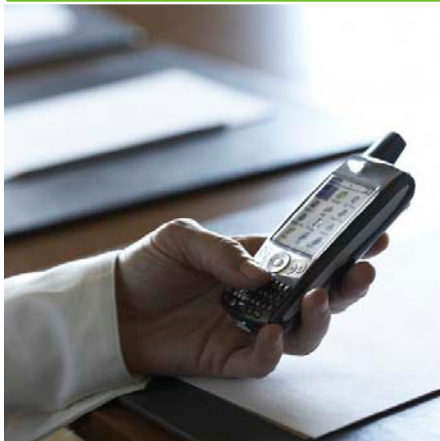

- Distance learning
- Medical consultation
- Remote monitoring for security & medical
- Video conferencing
- Video distribution

Where Integrated Services over IP Are Going

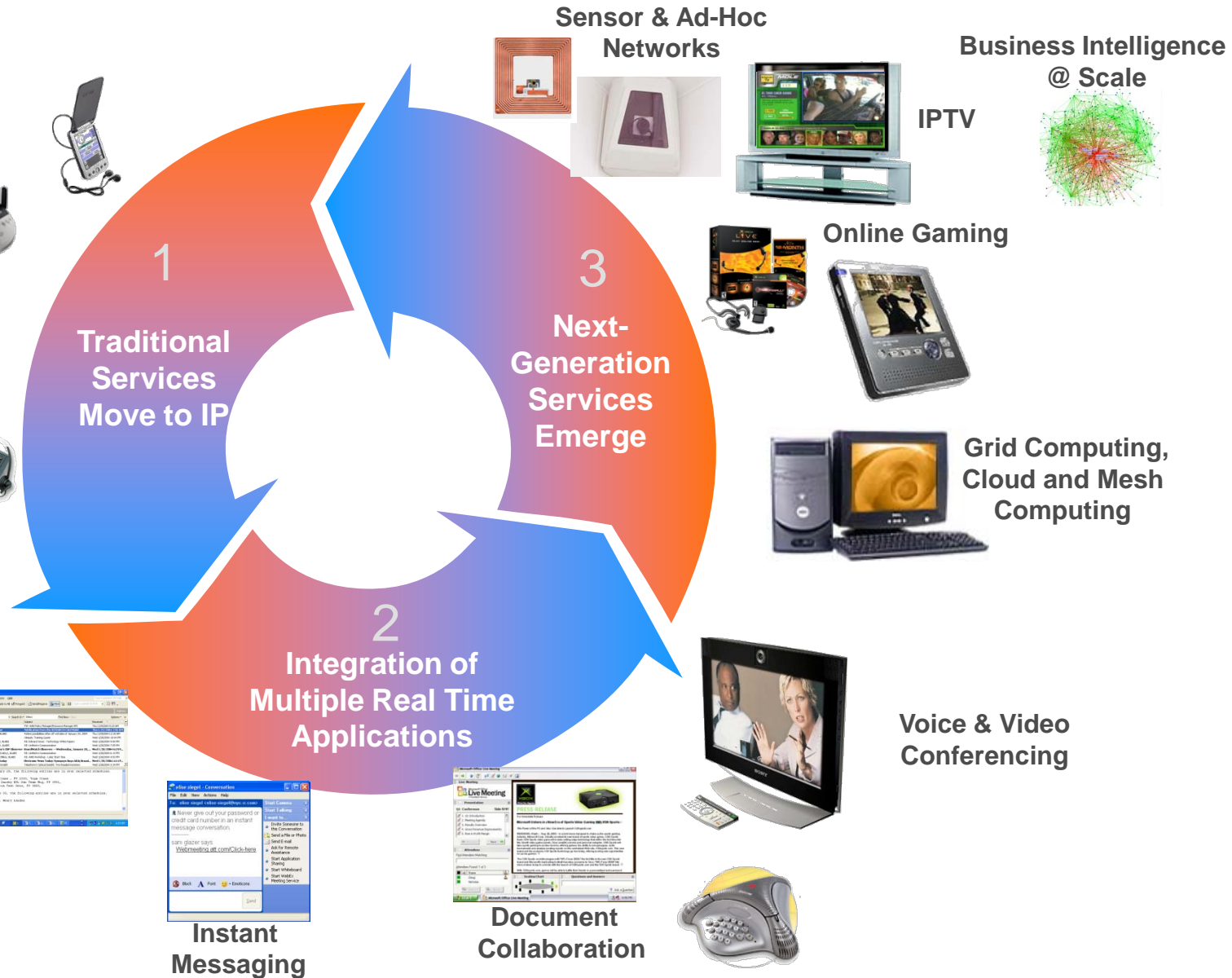

IP Enables the Next Generation of Applications

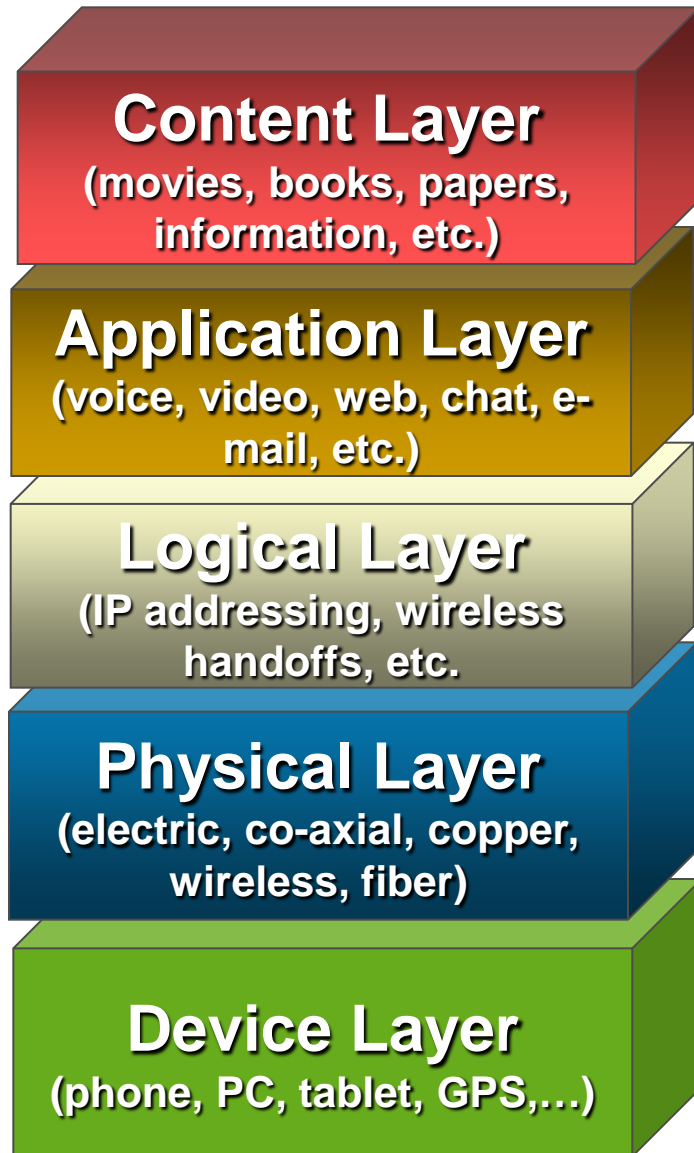

IP operates in layers that allow applications to be separated from the infrastructure

- Enables multiple players to enter the market at different layers and compete, stimulating innovation
- The type of the network (electric, co-axial, copper, wireless, fiber) no longer dictates the application or services

Players can enter the Market at Different Levels to Compete, Stimulating Innovation

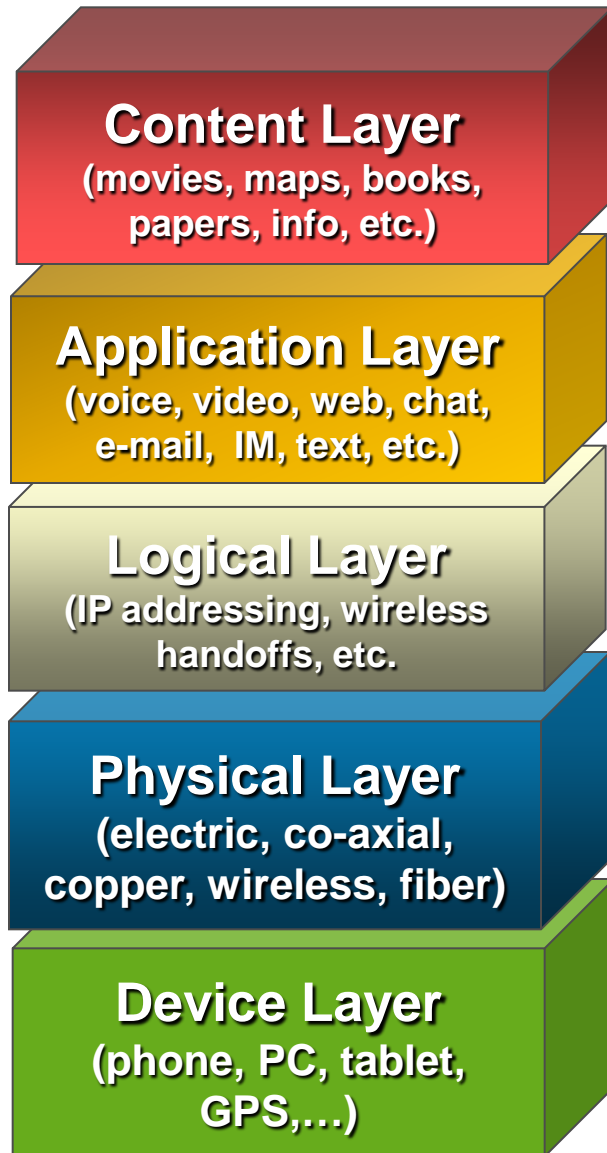

AT&T U-verse	Vonage VoIP	Garmin GPS	Amazon Kindle	Skype	Apple iPad
AT&T / content owners	Phone Number	Garmin / map, TMC traffic providers	Amazon / content owners		Apple / content owners
AT&T	Vonage	Garmin	Amazon	Skype	Apple / 100,000s application providers
AT&T	Cable & DSL	Satellite & FM radio	Amazon / Global 3G providers	Cable & DSL, Wireless	Apple / AT&T 3G or broadband wifi
AT&T	Cable & DSL	Satellite & FM radio	Amazon / Global 3G providers	Cable & DSL, Wireless	Apple / AT&T 3G or broadband wifi
AT&T / Set top box mfrs	Vonage VoIP box	Garmin GPS	PC, MAC, iPhone, Blackberry, iPad, Android	PCs, MAC, camera, cell phone mfrs	Apple iPad



Technology Demonstrations

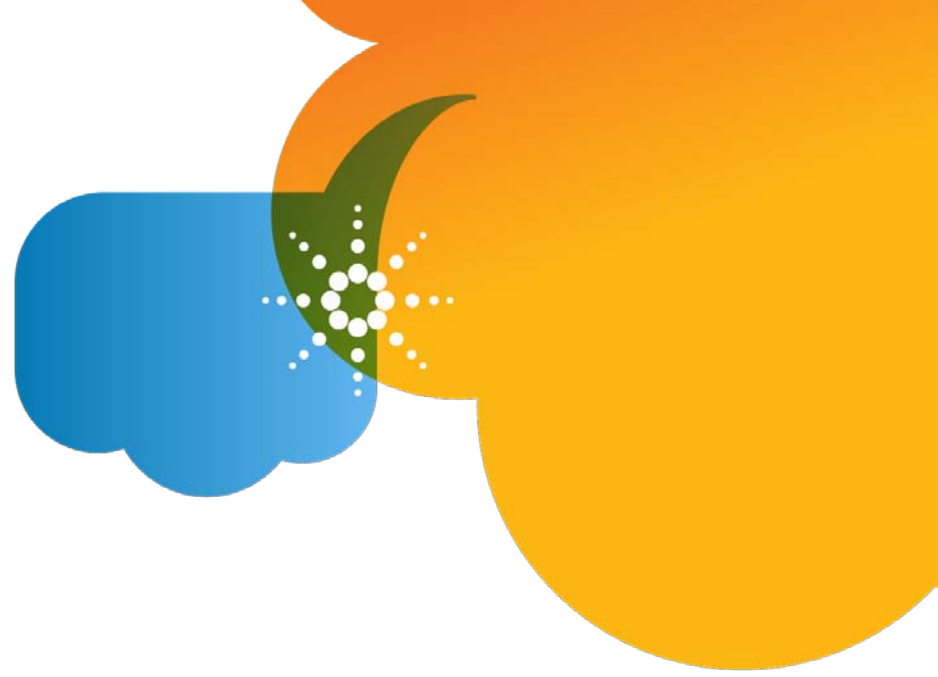

Voice over IP

Google Voice

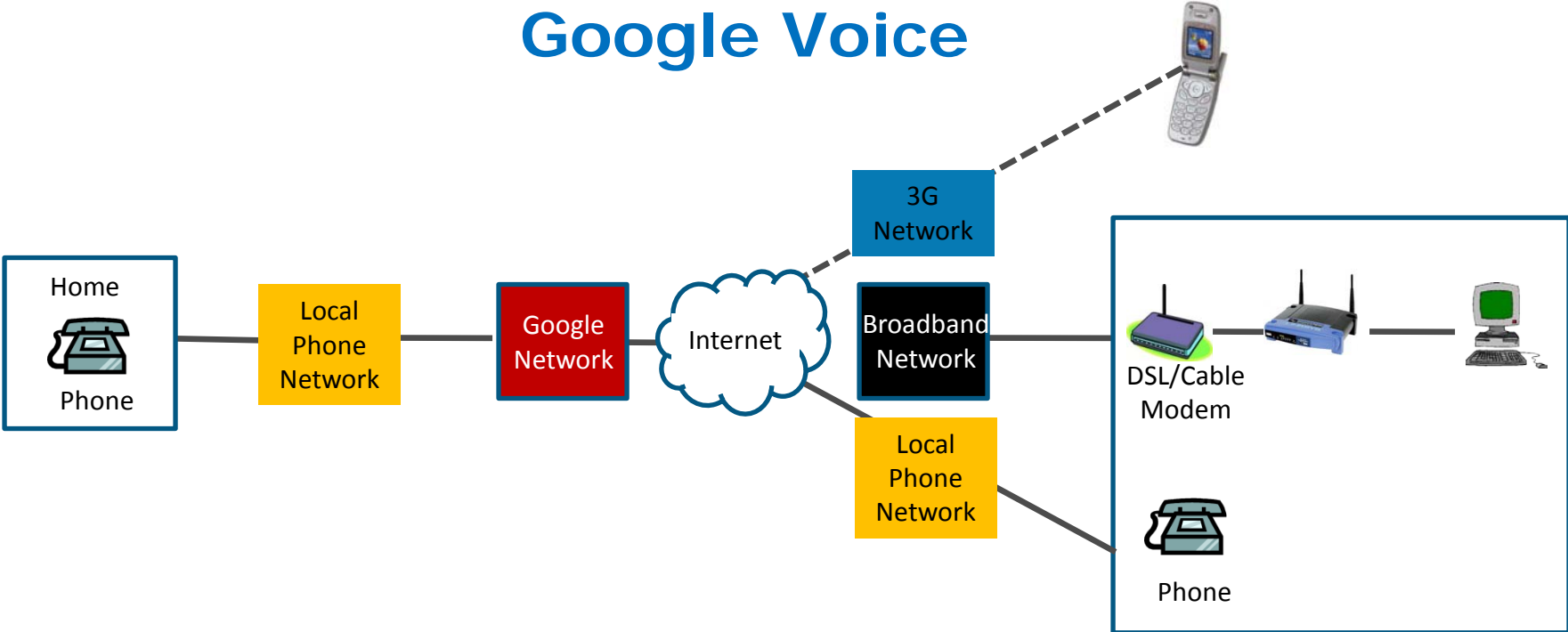

Ooma VoIP

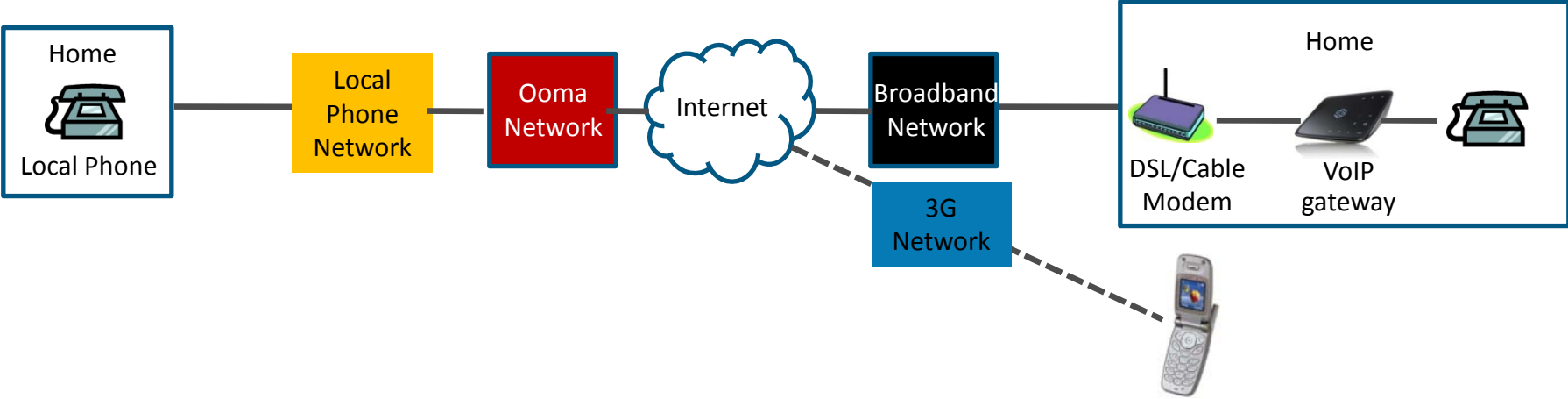

Google Voice

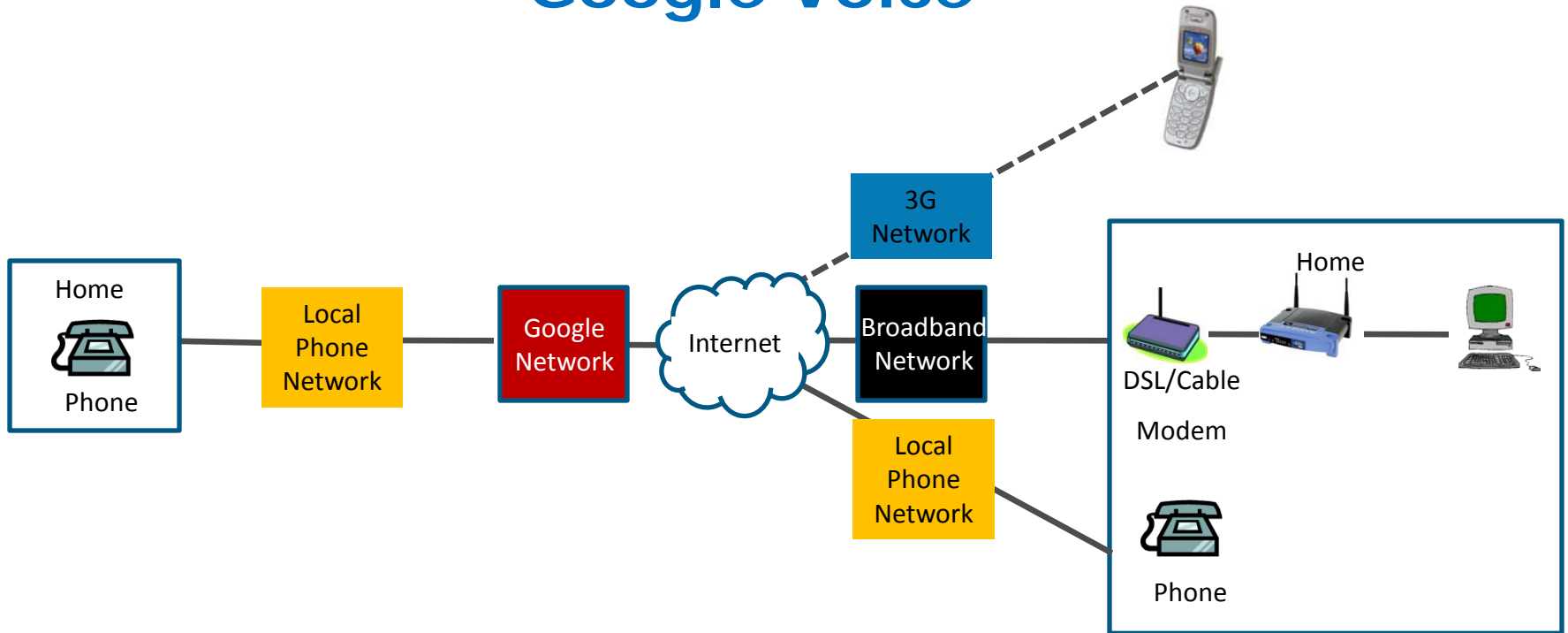

Consumer pays
Broadband Provider for
Broadband service

Consumer is provided a "google" number for all devices for free; pays Google for international calls

Ooma VoIP

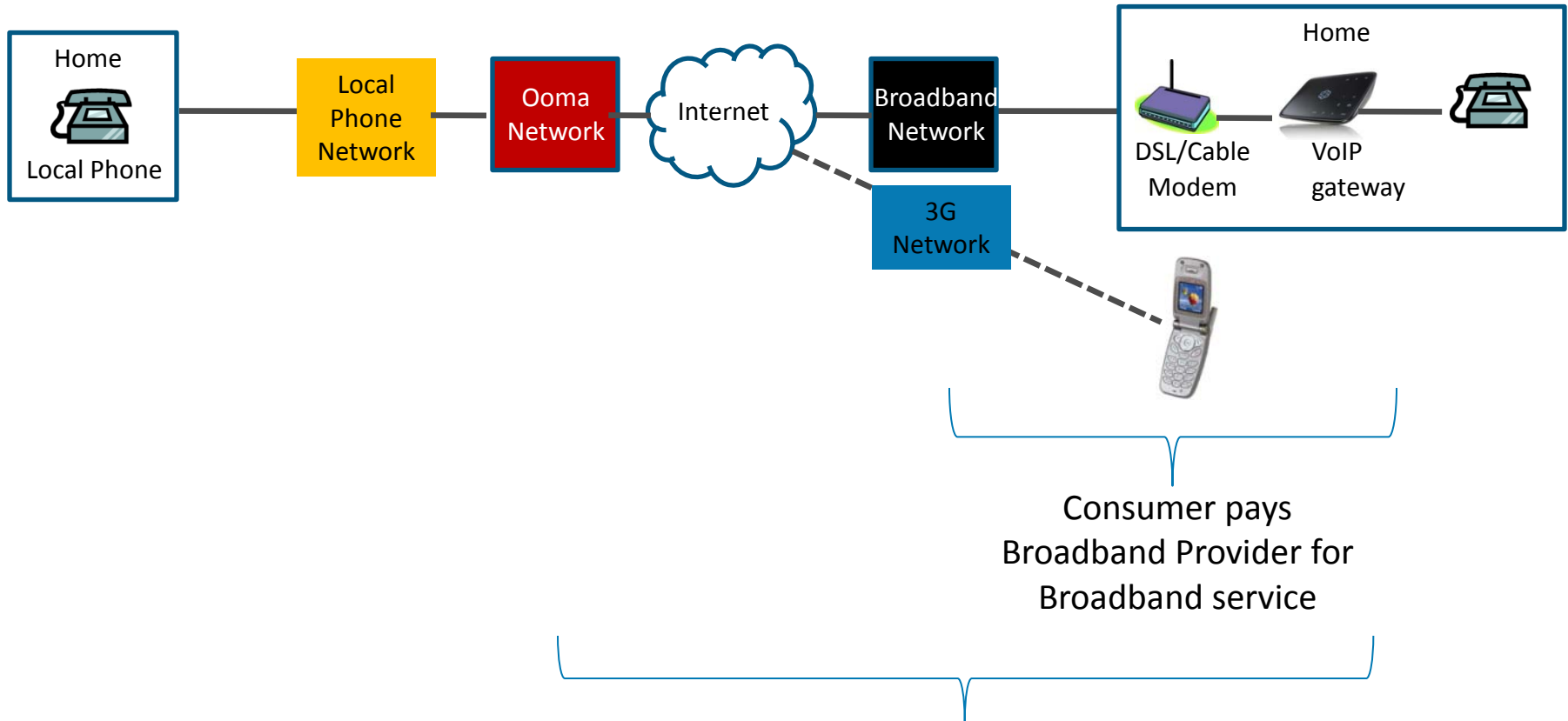

Consumer pays Ooma for (1) device with unlimited US local and LD calling, (2) optional monthly subscription fee for advanced phone features (3) optional rate plan for international calling

VoIP Growth

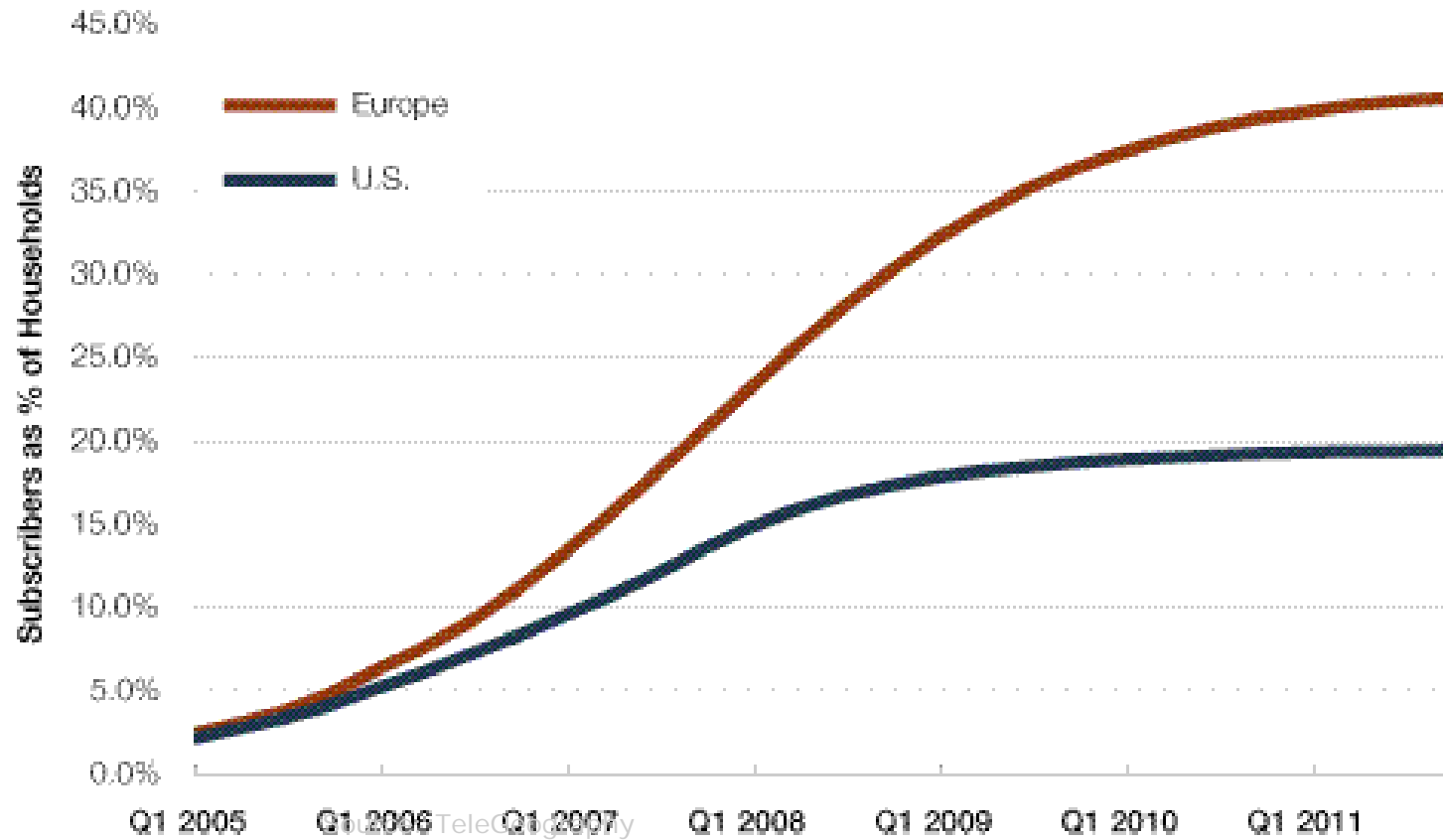

Source: TeleGeography

US Residential VoIP Market Forecast

Figure 1 Forecast: US Broadband Telephony Households By Platform, 2009 To 2014

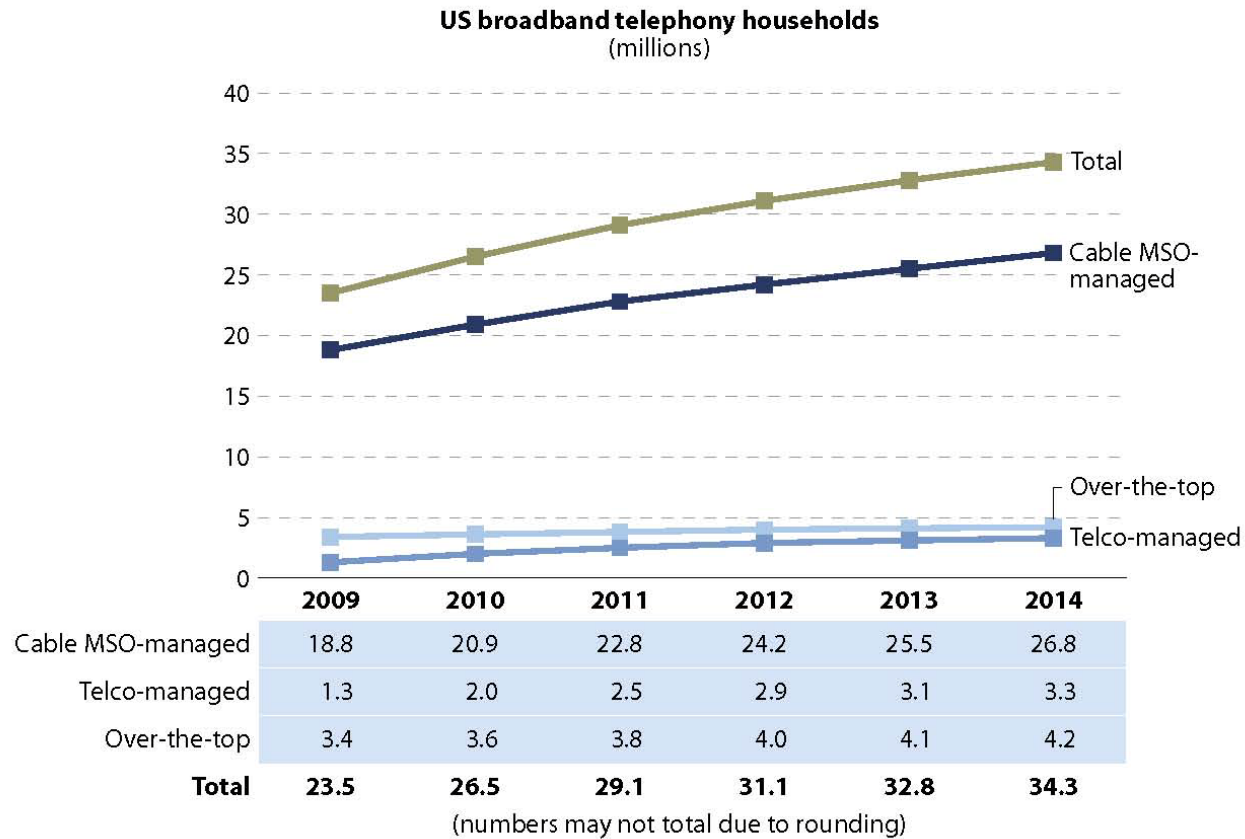

Source: Forrester Research Broadband Telephony Forecast, 10/09 (US)



Video Calling/Conferencing

Skype

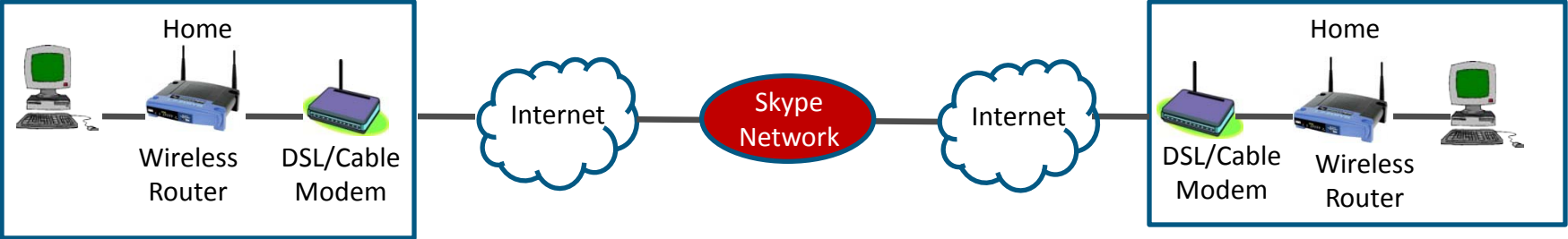

AT&T Connect

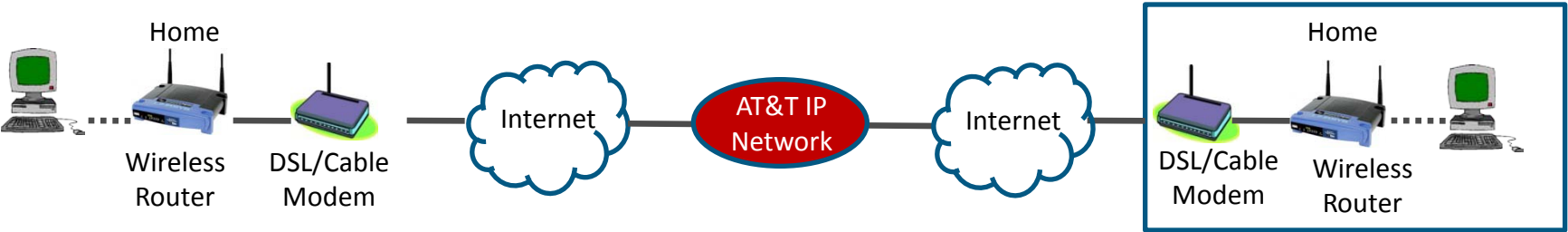

Skype

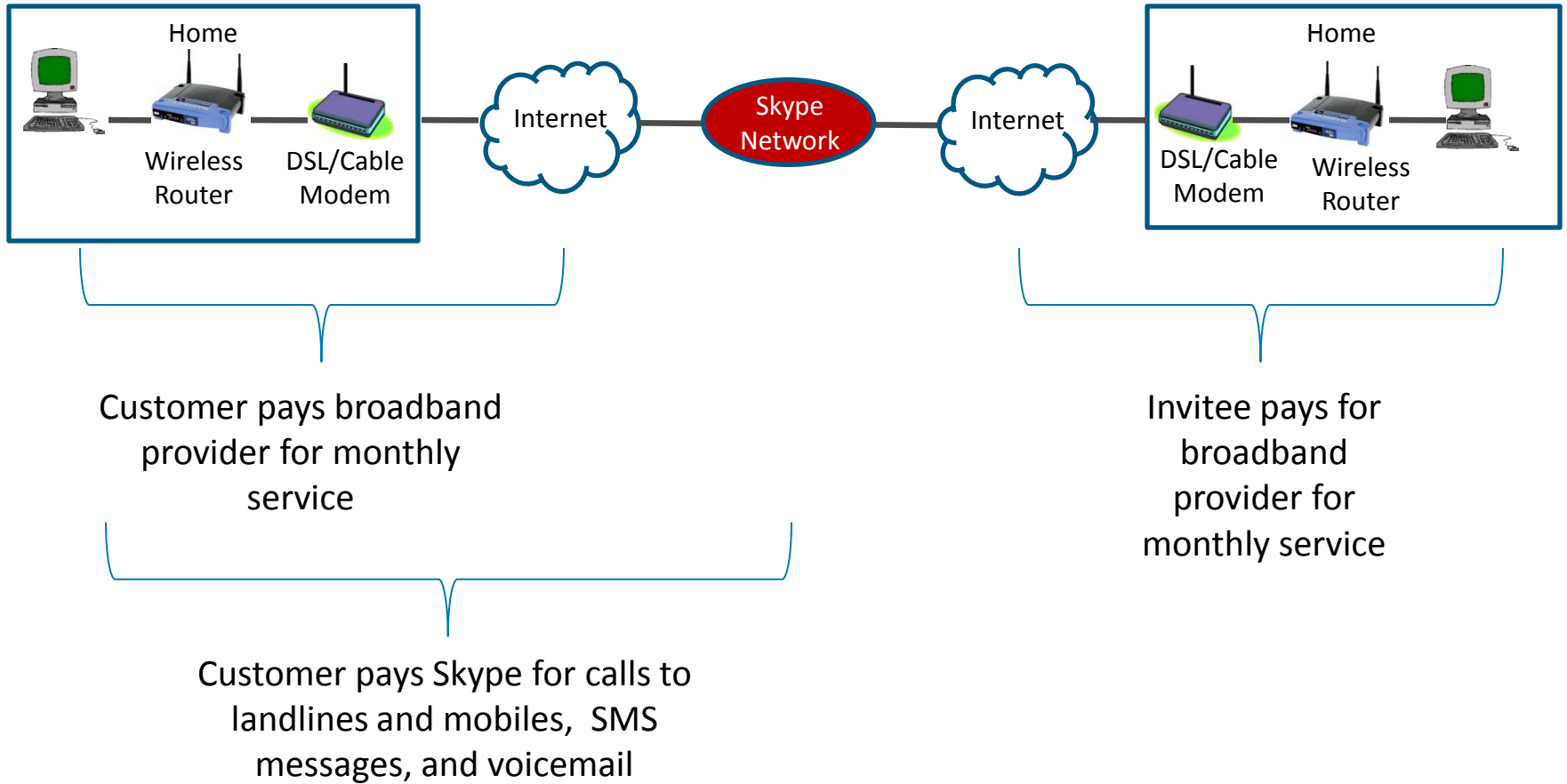

AT&T Connect

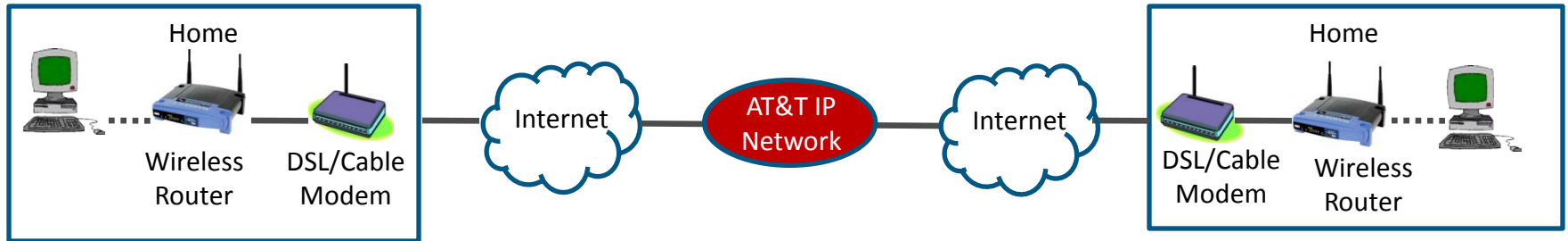

Teletworker pays
broadband provider for
monthly service

Invitee pays for
broadband
provider for
monthly service

Teletworker's company pays AT&T a
monthly invoice based on contracted
rates; have the option to have audio
portion via phone

Skype Growth

Skype Growth
from 2005 to 2009

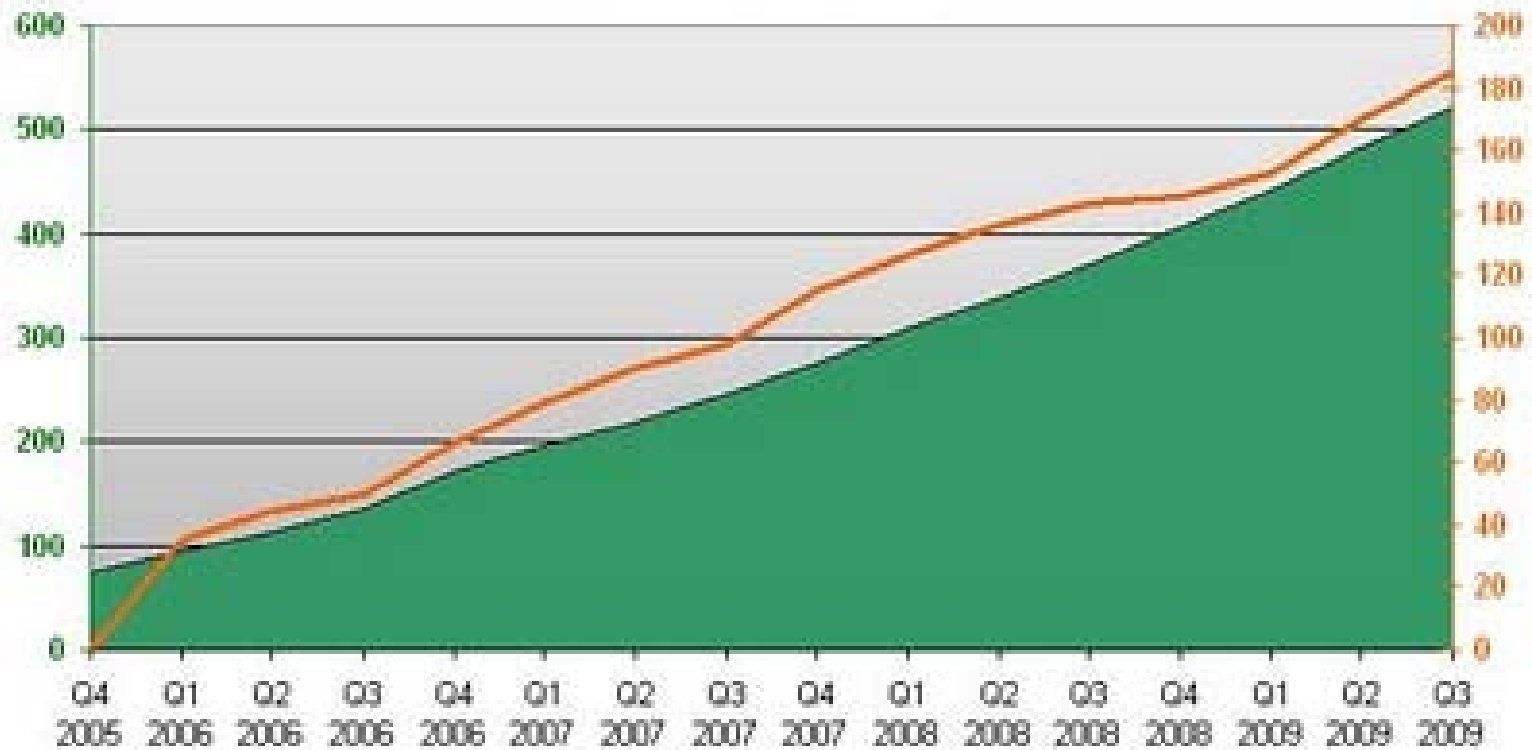

Source: NO Logic 2010

Total user accounts (in million)

Revenue US\$ (in million)

International Voice Traffic

Skype's Share of International Long-Distance Traffic, 2009

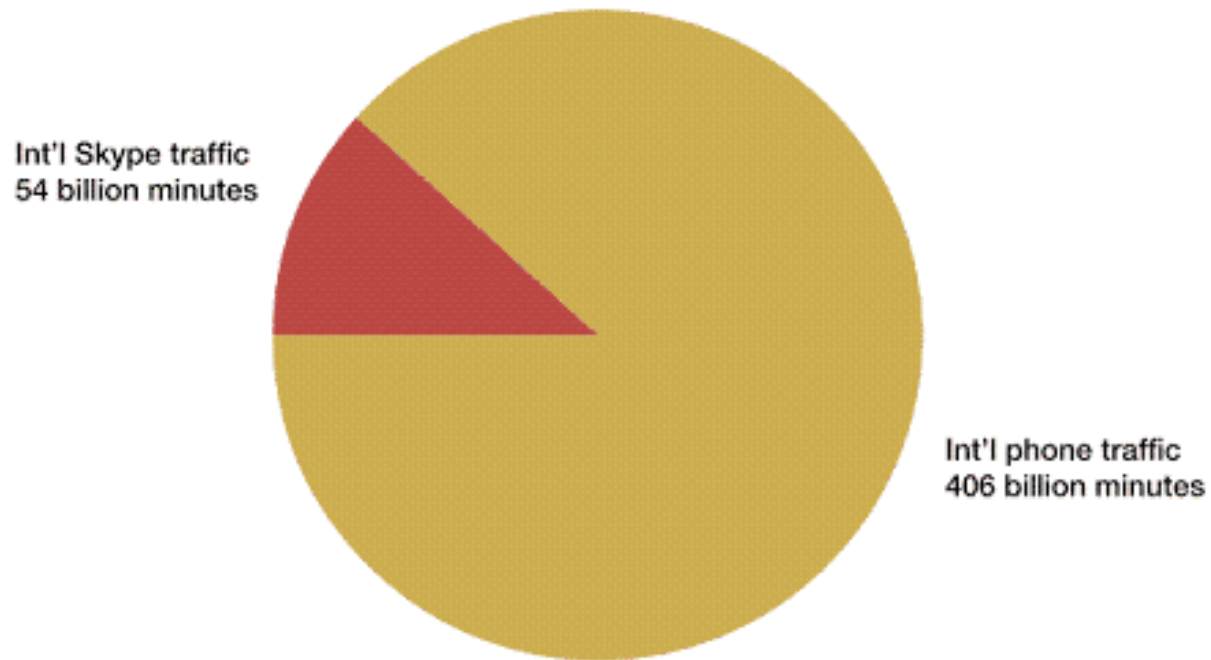

Source: TeleGeography

©2010 PriMetrica, Inc.

IP Television

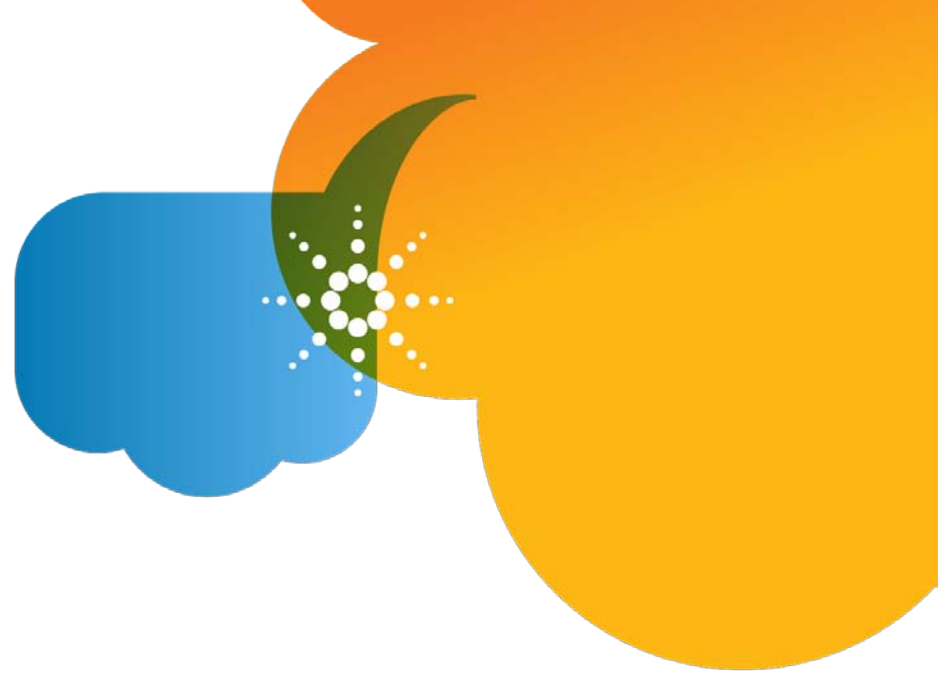

Hulu IP Video

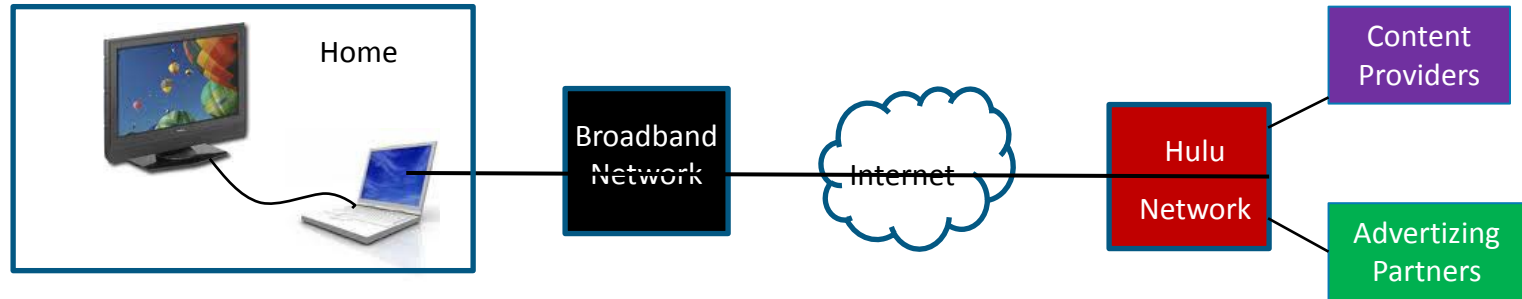

AT&T U-verse IPTV

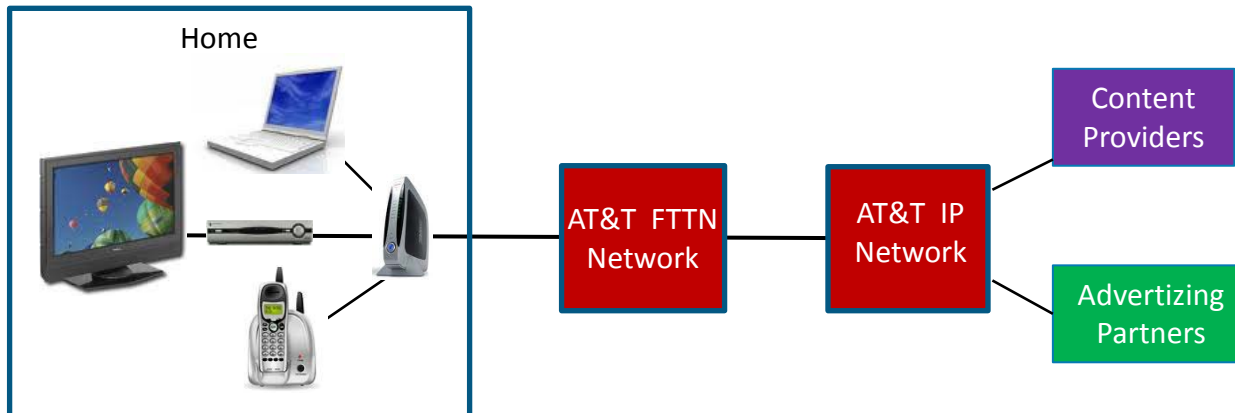

Hulu IP Video

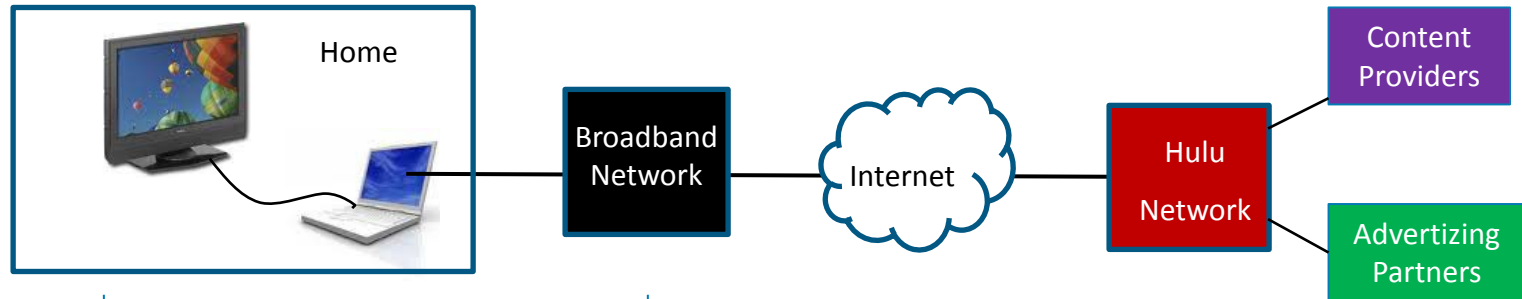

Customer pays broadband provider for monthly service

Customer gets basic service free which includes upfront ad; optional premium service with a monthly charge just announced

Hulu Video Views and Unique Viewers

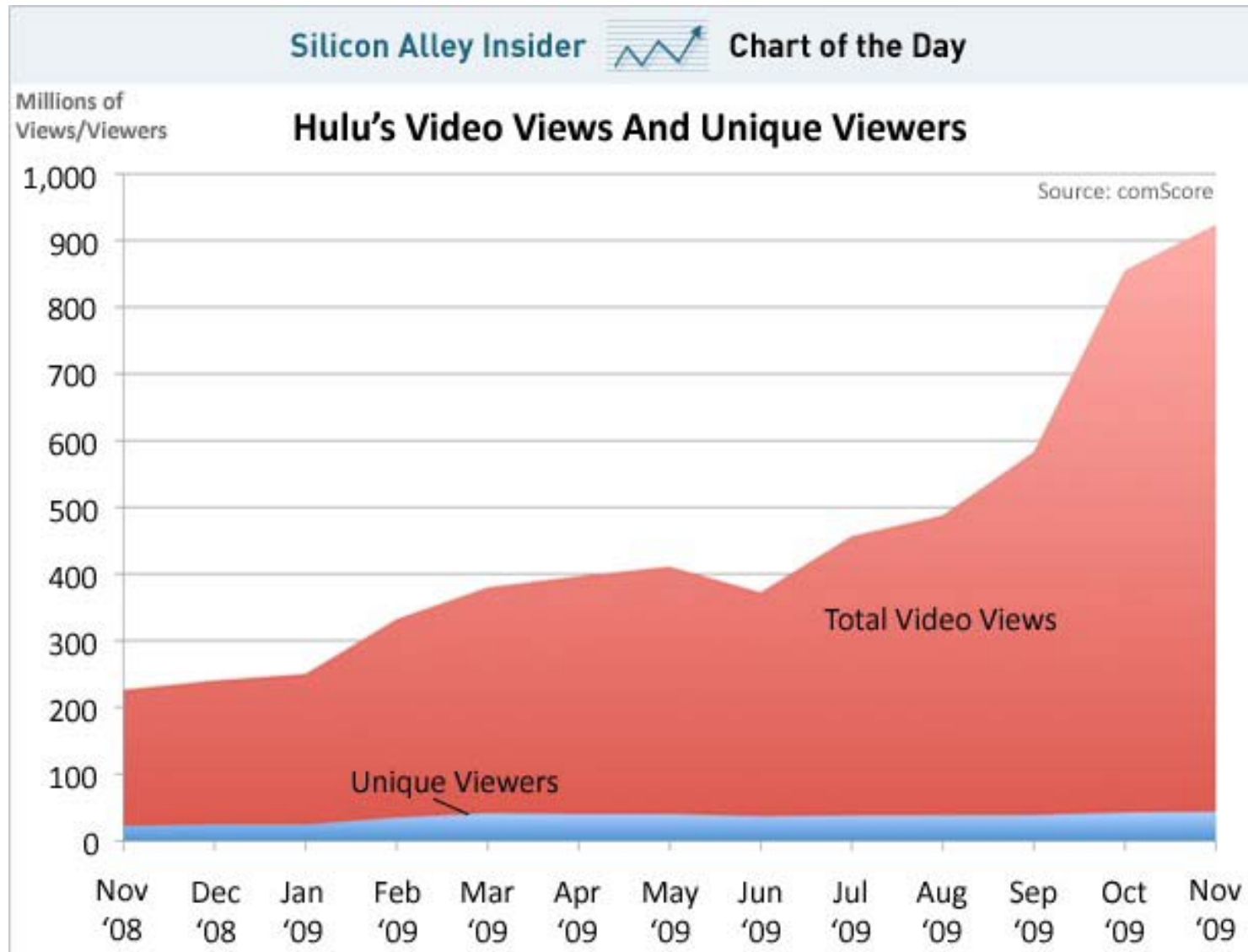

AT&T U-verse IPTV

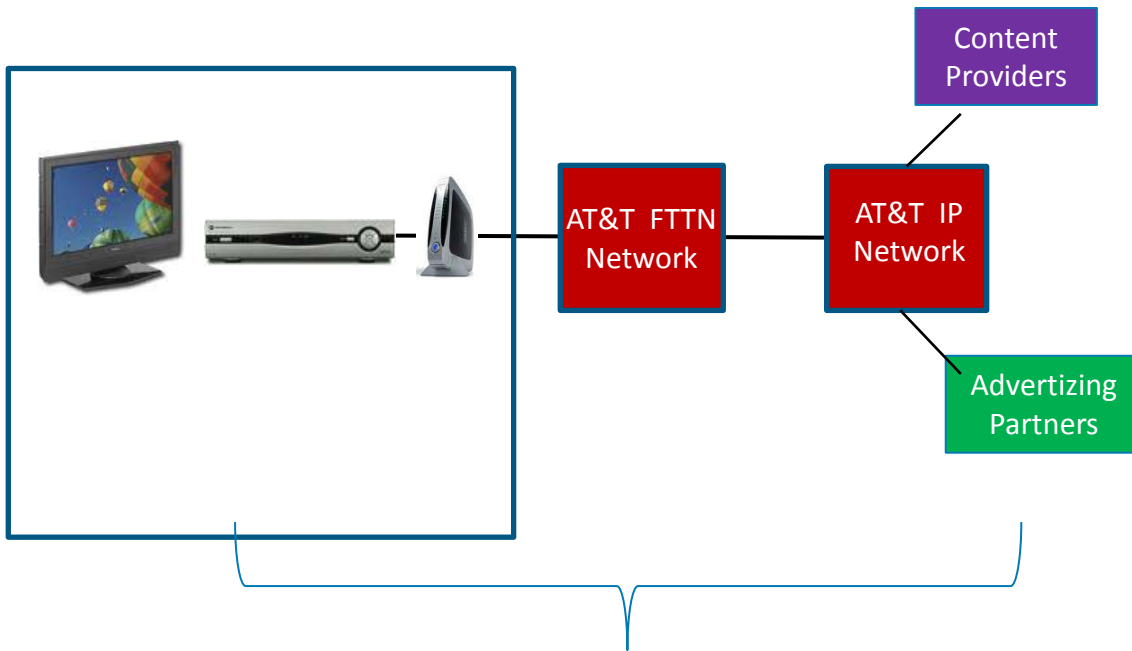

Customer pays AT&T for monthly TV & broadband;
VoIP phone optional

U.S. Telco/ISP TV Subscribers

U.S. Telco/ISP TV Subscribers

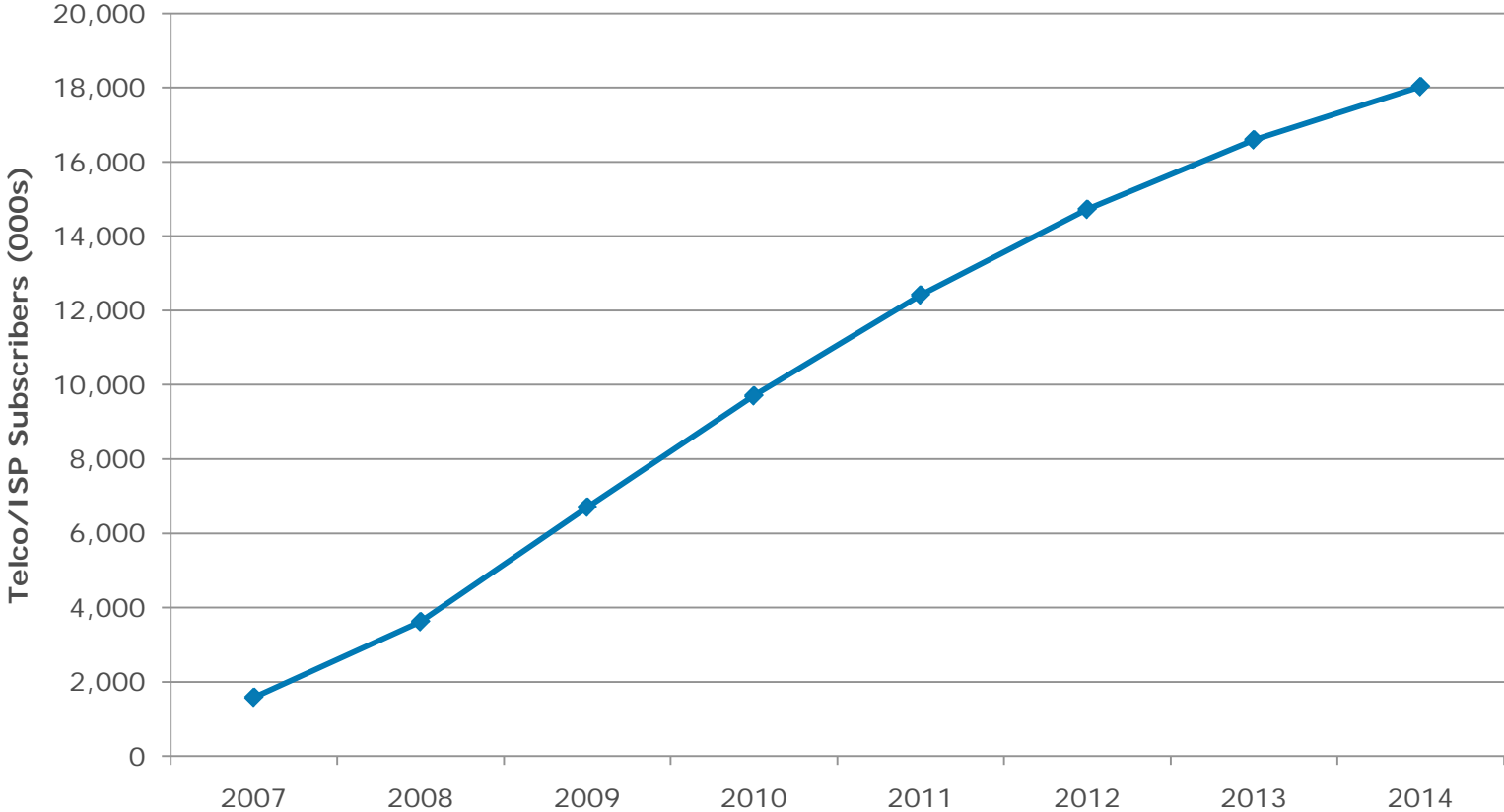

Source: Ovum

Jonathan Doran, August 2009

IPTV via Slingbox

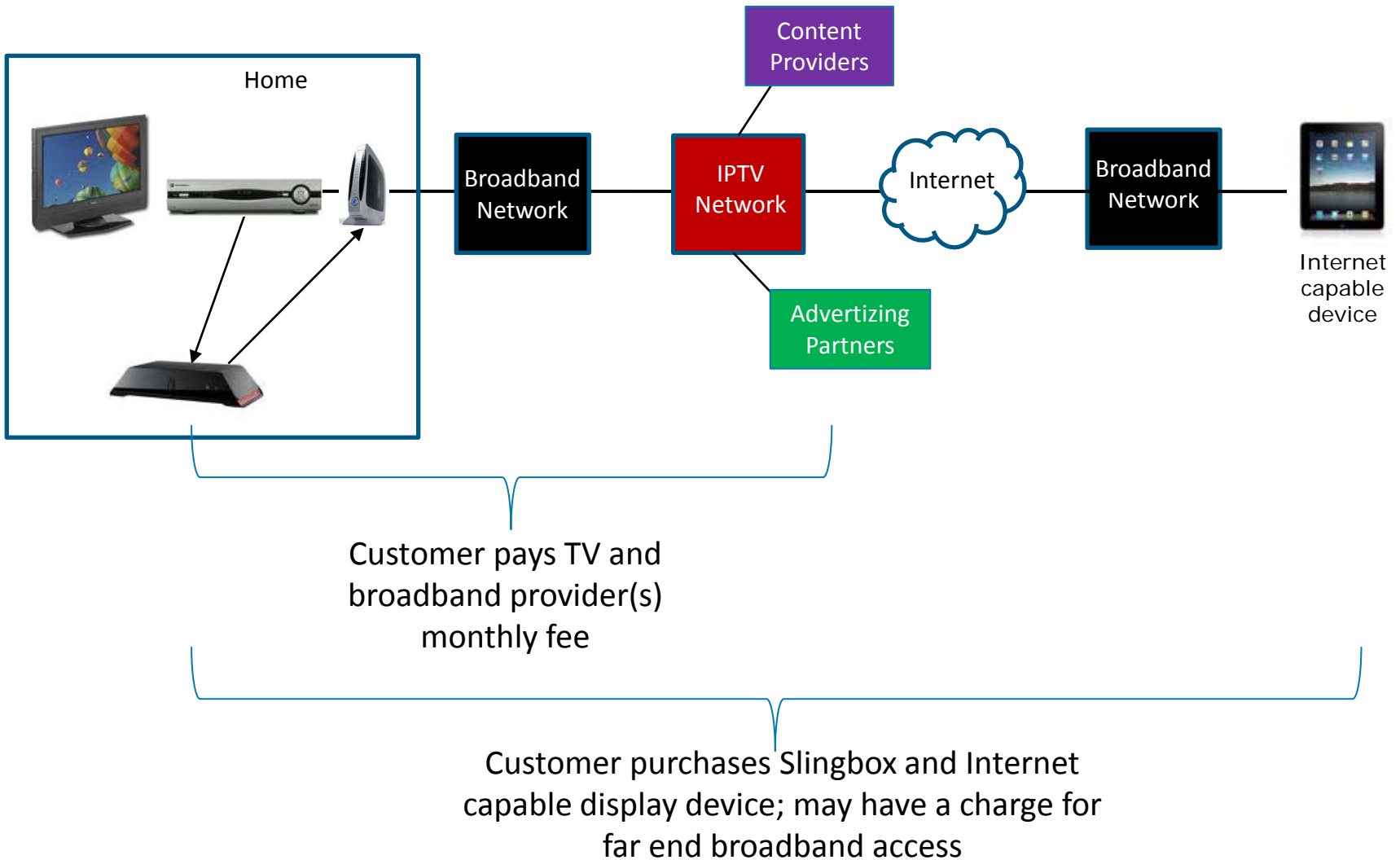

U.S. Mobile TV/Video Market Forecast

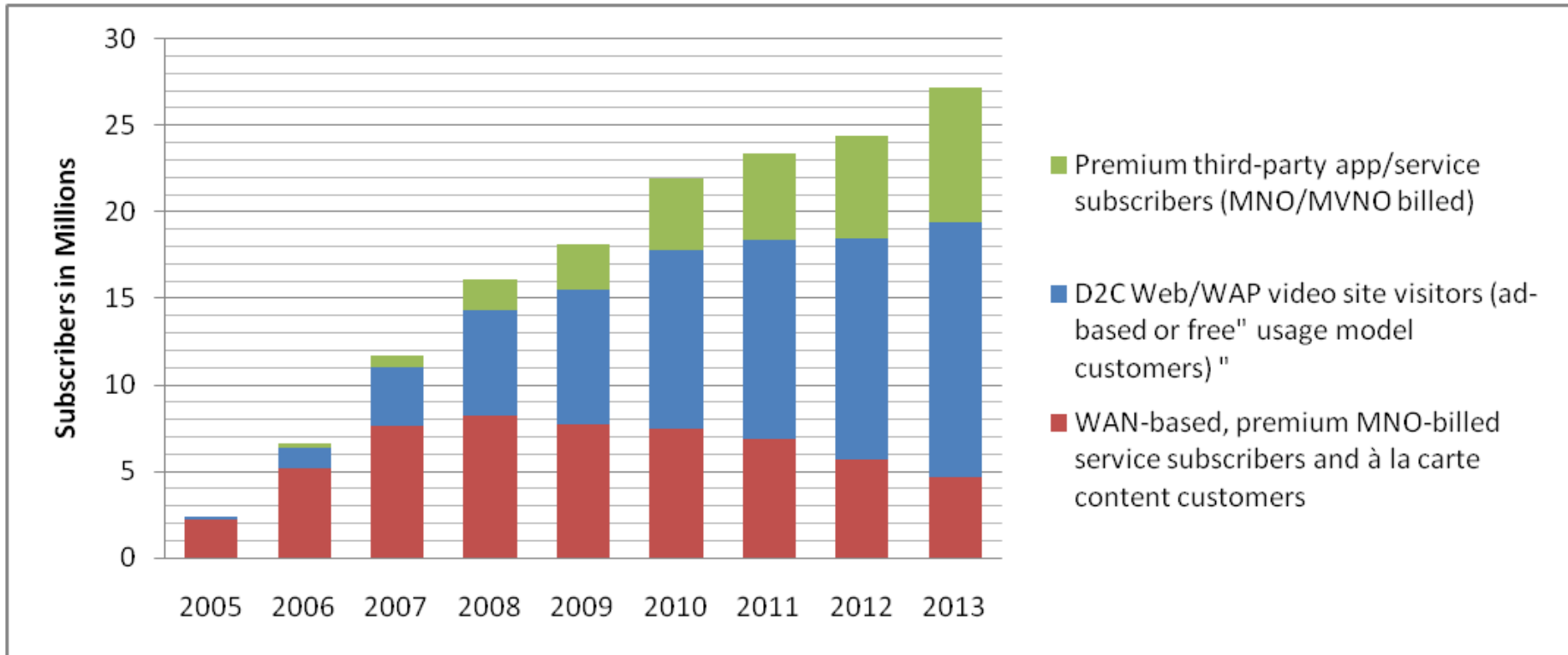

Source: IDC MARKET ANALYSIS

U . S . Mobile Video and Television 2 0 0 9 – 2 0 1 3 Forecast

IP: Key Driver to the Realization

of Any Application from Any Device to Any Device over Any Network

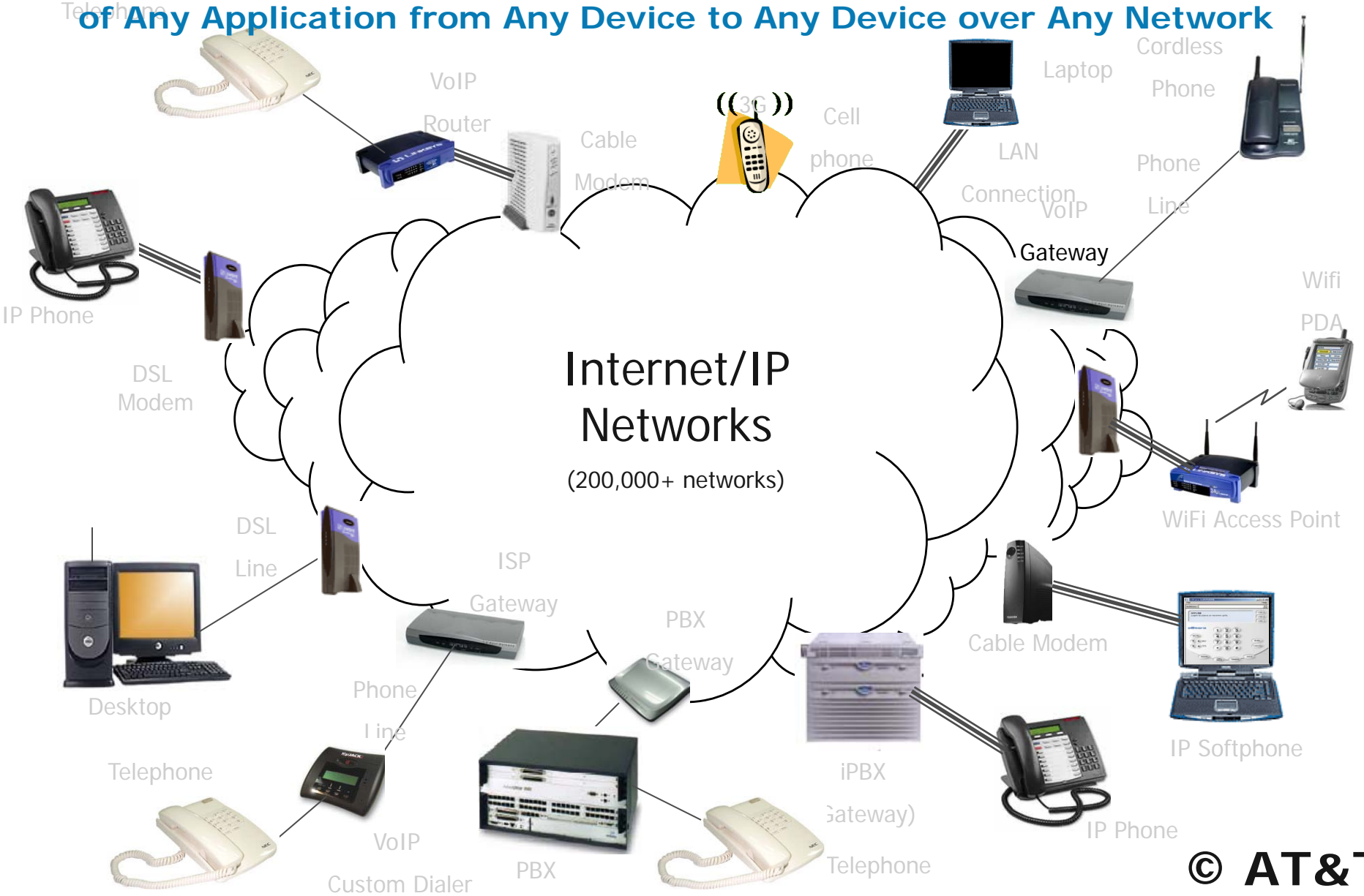

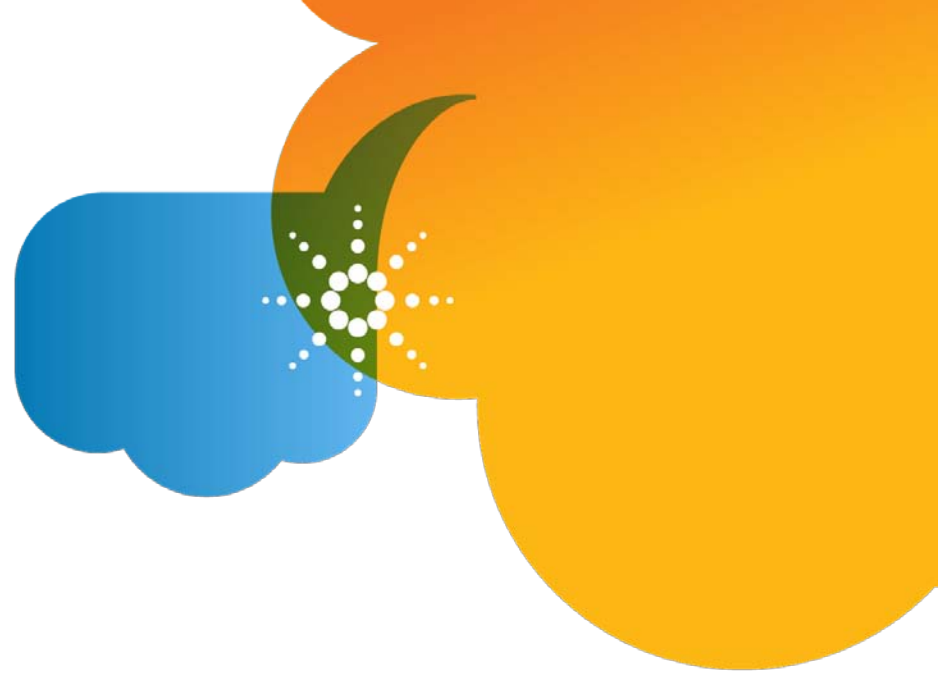

Questions?